

JWB系列滚珠丝杠升降机选型手册

JWB型 (普通滚珠丝杆型)

高速 高频率

JWB型 (普通滚珠丝杆型), 适用于高速, 高频率和高性能的装置中, 主要构成部件为精密滚珠丝杆副与高精度蜗轮蜗杆副。

- 1) 高效率: 只需很小的驱动源, 就可以产生很大的推动力。
- 2) 高速化: 与梯形丝杆相比, 速度有很大的提高, 能轻松而高速地运转。
- 3) 使用寿命长: 采用高质量的滚珠丝杆, 使其工作寿命提高3倍以上。

注: 本身无自锁功能, 需外加制动装置或选择带有制动的驱动源。

JWB (General ball screw)

HIGH SPEED HIGH FREQUENCY

JWB (General ball screw) is suitable for high speed, high frequency and excellent performance.

Main components: Precision ball screw pair and high precision worm-gears pair.

- 1) High efficiency
Rolling friction improve efficiency greatly, only a little drive power can generate great thruust force.
- 2) High speed
Rolling friction speed up travel of screw easily.
- 3) Lifetime longer
High precision ball screw can make JWB's lifetime longer by 3 times comparing with JWB.

Note: Braking devices or motor with braking devices are necessary when choosing JWB.

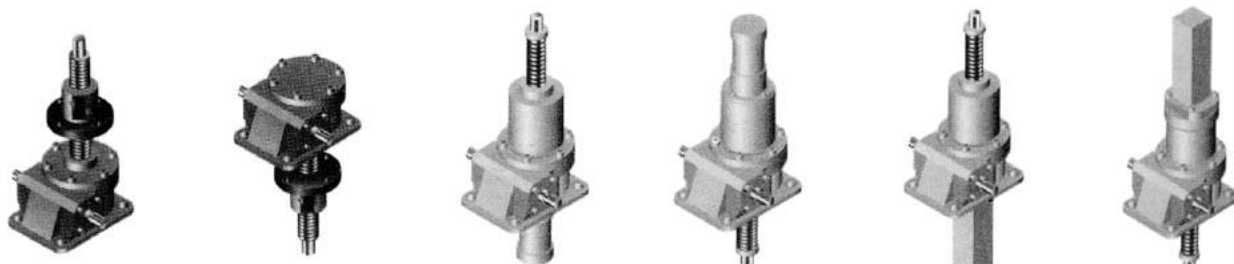

JWB (普通滚珠丝杆) 基本参数一览表

JWB (General ball screw) basic parameter table:

型号 Type		JWB010	JWB025	JWB050	JWB100	JWB150	JWB200	JWB300	JWB500
最大载荷 Maximal load	(kN)	9.80	24.5	49.0	98.0	147	196	294	490
丝杆外径 Outer diameter of screw	(mm)	20	25	40	50	55	65	80	100
丝杆底径 Small diameter of screw	d (mm)	17.5	21.4	31.3	39.1	43.1	55.7	74.8	87
丝杆螺距 Pitch of screw	L1 (mm)	5	8	10	12	12	12	16	20
减速比 Ratio i	H速度 Speed	5	6	6	8	8	8	10 $\frac{2}{3}$	10 $\frac{2}{3}$
	L速度 Speed	20	24	24	24	24	24	32	32
综合效率 % Integrated efficiency η	H速度 Speed	61	62	64	63	63	62	56	60
	L速度 Speed	34	35	39	43	43	41	34	38
容许输入最大功率 Permissible output maximal power (kW)	H速度 Speed	0.54	1.3	2.2	3.6	4.0	5.5	8.9	13.3
	L速度 Speed	0.27	0.63	1.0	1.9	2.1	2.8	4.1	6.5
空载扭矩 No-load torque T_0	(N·m)	0.29	0.62	1.37	1.96	2.65	3.92	9.81	19.6
保持扭矩 Keeping torque (N·m)	H速度 Speed	1.27	4.31	10.78	19.6	39.2	51.0	68.6	140.1
	L速度 Speed	0.26	0.91	2.4	5.8	11.8	15.0	19.5	41.2
容许输入轴扭矩* Permissible torque of input shaft	(N·m)	19.6	49.0	153.9	292.0	292.0	292.0	735.0	1372.0
最大载荷时所需输入轴扭矩** (N·m) Required torque of input shaft at maximal load	H速度 Speed	2.8	9.0	21.5	39.1	77.0	104.5	169.6	317.5
	L速度 Speed	1.4	4.3	9.6	20.4	39.6	54.2	98.5	177.9
输入轴每回转一圈对应丝杆 (活动螺母) 轴向位移量 Axial displacement of screw, when input shaft rotate a circle. (mm)	H速度 Speed	1	1.33	1.67	1.5	1.5	1.5	1.5	1.88
	L速度 Speed	0.25	0.33	0.42	0.5	0.5	0.5	0.5	0.63
最大载荷时容许输入轴回转速度 Permissible rotational speed of screw shaft at maximal loading (rpm)	H速度 Speed	1500	1400	1000	890	500	500	500	400
	L速度 Speed	1500	1400	1000	890	500	500	400	350
最大载荷时丝杆回转扭矩 (N·m) Rotational torque of screw at maximal load		8.7	34.7	86.7	208.2	416.3	555.1	1040.9	2081.7

* 减速机输入轴的容许扭矩。(连续运转时请确认)

**包括无负荷空转扭矩的数值。

* Permissible torque of shaft of reducer.

** Include torque under the condition of no-load operating.



应用示例：
两台联动：

Application example:
Two gear boxes linking:

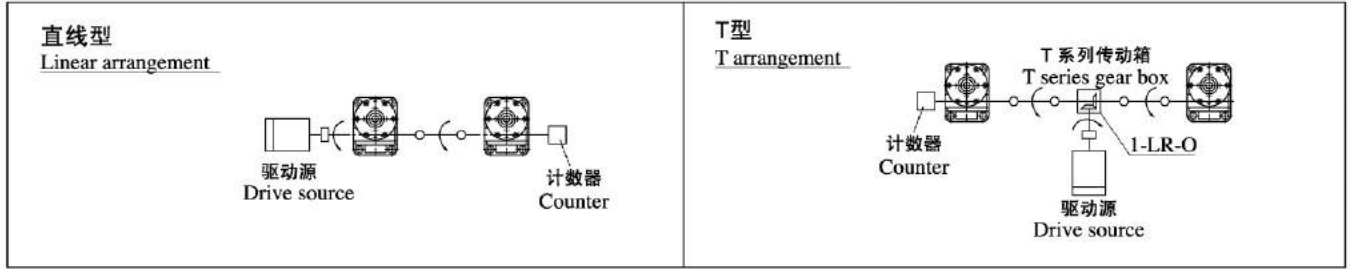

四台联动：

Four gear boxes linking:

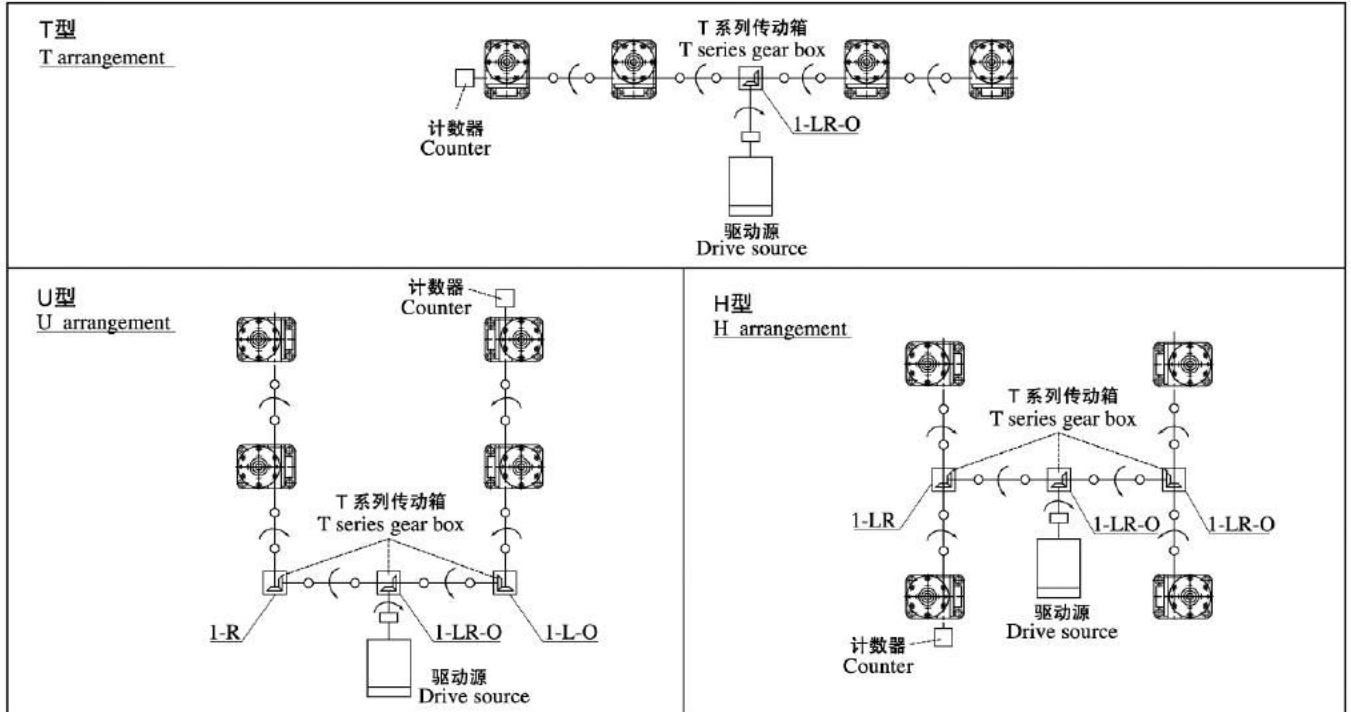

八台联动：

Eight gear boxes linking:

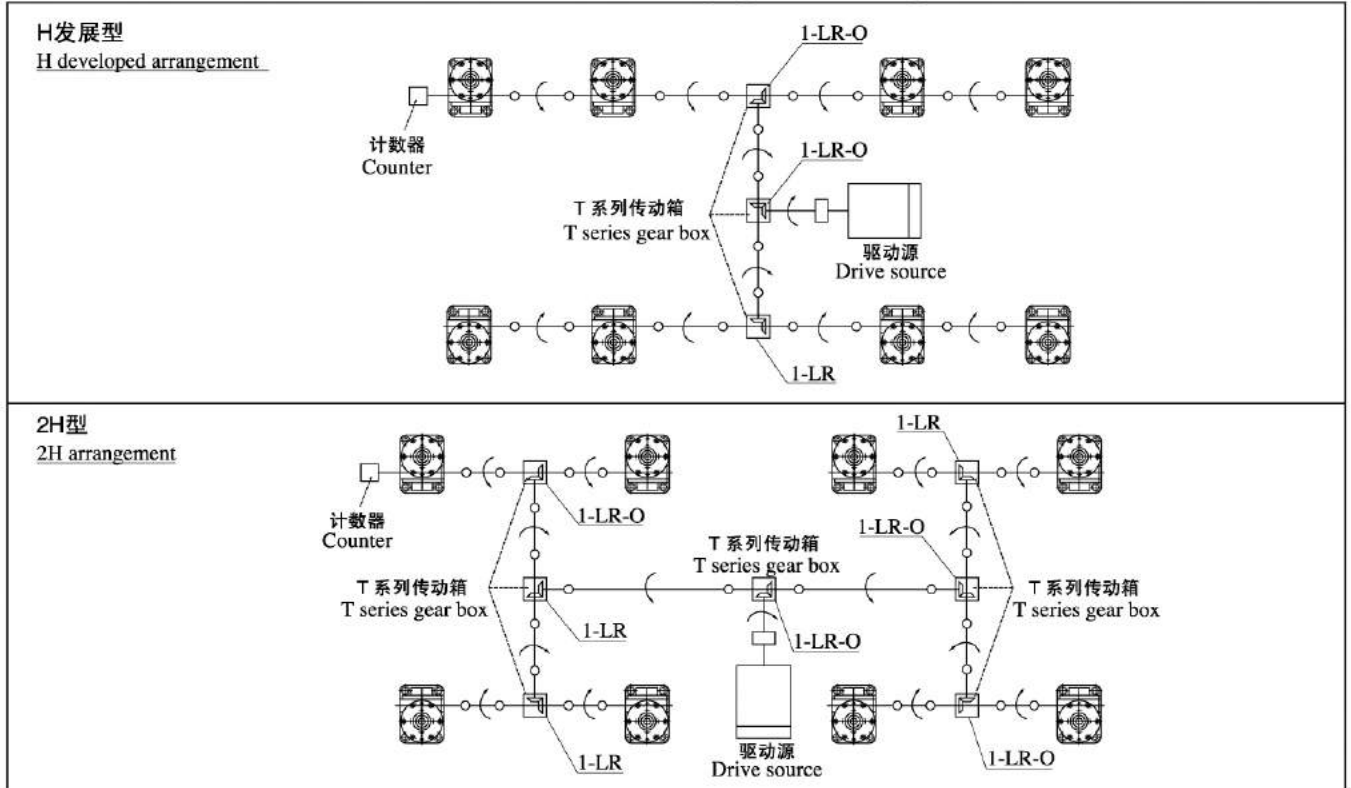



注意事项:

- 1) 选择升降机时不论静载、动载、冲击载荷均不得超过其允许承受的最大载荷, 根据安全系数、使用行程、校对丝杆的稳定性选择具有充分容量的升降机;
- 2) 一定要注意丝杆轴转速与承受的载荷进行搭配, 对于升降机的容许最大载荷、容许外加负载、容许丝杆轴的旋转速度等项目进行校验, 如果超过产品的数据将会造成升降机设备整体的重大损伤;
- 3) 升降机在工作时其减速部表面温度应控制在-15℃~80℃的范围以内, 确保活动螺母的表面温度也在上述范围以内;
- 4) 输入轴容许转速为1500r/min, 输入轴不得超过此转速;
- 5) JWM和JWB都不可连续运转:
单台升降机的负荷时间率(%ED)以30分为单位计算, JWM(梯形丝杆类型)的负荷时间内不得超过20%ED, JWB(普通滚珠丝杆)的负荷时间率不得超过30%ED,

负荷时间率%ED =

$$\frac{1 \text{ 动作周期的工作时间}}{1 \text{ 动作周期的工作时间} + 1 \text{ 动作周期的停歇时间}} \times 100\%$$

- 6) 对于在同一轴线上连接数台升降机时, 请务必对输入轴强度进行校核, 使每台升降机所承担的扭矩都应在其容许输入轴扭矩以内;
- 7) 驱动源的起动扭矩应确保在使用扭矩的200%以上;
- 8) 在零摄氏度以下工作时因受润滑油粘性变化的影响使得整机效率下降, 所以必须选有充足的驱动源;
- 9) JWM型理论上具有自锁功能, 但工作在振动冲击较大的场合时会导致自锁功能失灵, 因此须外加一制动装置或选择带有制动的驱动源。
JWB型升降机构本身不具有自锁功能, 为了防止由于轴向载荷和丝杆的自重而产生逆转, 必须外加制动装置或选择带有制动的驱动源, 请确保制动扭矩大于保持扭矩;

10) 升降机使用的环境如下

使用场所	Working Location	室内无雨水侵入的场所	Indoor location without rainwater
周围空气	Ambient Air	灰尘为一般工厂状态	Normal
环境温度	Ambient Temperature	-15℃~40℃	
相对湿度	Relative Humidity	85%以下	Less than 85%

- 11) 当升降机工作在多灰尘的场所中时请务必选择防尘罩伸缩套附件来保护丝杆, 在室外使用时请务必考虑使用罩壳等装置, 使机器不直接受到风吹雨打;
- 12) 在升降机工作时, 不得进行人为的强行停机, 否则将使升降机受到严重破损;
- 13) 在有负载的情况下, 请不要将JWB型的输入轴驱动方式变为手动操作, 负载有可能会造成输入轴旋转非常危险。

Note:

- 1) Select a Jack with sufficient capacity according to safety factor, service journey and stability. And stationary load, dynamic load and shock load must be lower than permissible maximum load.
- 2) Please note that rotation speed of screw must match load, permissible maximum load, permissible maximum outer load, and permissible rotation speed of screw must be verified. If these figures exceed that of products, jacks will be damaged greatly.
- 3) The surface temperature will be limited in -15° ~ 80° when jack working to ensure the temperature of traveling nuts in -15° ~ 80° .
- 4) Maximum input speed is 1500r/min.
- 5) JWM and JWB aren't suitable for continuous operation, Jack Duty(%ED) JWM duty(%ED) cannot exceed 20%ED, JWB duty(%ED) cannot exceed 30%ED,

Duty %ED =

$$\frac{\text{jack operating time(lift \& lower cycle)}}{\text{Elapsed cycle time}} \times 100\%$$

- 6) When several Jacks are connected on the same axial line, the loaded torque with each Jack must be verified and limited within permissible input torque.
- 7) Starting torque must be 200% of service torque.
- 8) At below 0° ambient temperature, changed adhesion of lubrication will lower Jack's efficiency so that sufficient drive is necessary.
- 9) JWM has self-lock function, but an Extra braking device or drive source with braking device is necessary to be equipped because self-lock will be of mal-function when Jack is loaded a heavy shock.
JWB has no self-lock function, to avoid backspin of screw under axial load and its weight, a braking device or drive source with braking device is necessary to be equipped and braking torque must be larger than operating torque of Jack.

10) Jack's operating conditions

- 11) When working in dusty space, Jack must be equipped with elastic dust-hood on screw; in open air, shield must be equipped to prevent exposure to wind and rain.
- 12) When working, Jack cannot be forced to stop, or it will be damaged seriously.
- 13) Under load, don't change motor drive mode into manual drive, or which will cause backspin of screw and cause great danger.



选型方法:

How to select type:

升降机型号的确定:

Determine Jack's type:

计算总机的当量载荷Ws (N)

Calculate total equivalent load Ws (N):

$$W_s = \text{最大载荷 } W_{\max} \times \text{使用系数 } f_1(N)$$

$$W_s = W_{\max} \times f_1$$

被驱动设备系数 (f1) 表:

Service factor for driven machine (f1):

载荷性质 Load character	使用举例 Example	被驱动设备系数 Factor for driven machine (f1)
无冲击载荷, 负荷惯性小 shockless load & small inertia load	开关、阀门传送带切换装置 Switch, valve transmission belt swithing device	1.0 ~ 1.3
轻微冲击载荷, 负荷惯性中等 moderate shock & moderate inertia	各种移动装置, 升降用各种升降机 All kinds of moving devices, all kinds of elevators	1.3 ~ 1.5
大冲击振动载荷, 负荷惯性大 heavy shock & large inertia	用台车搬运东西; 保持压延滚轮的位置 Carrying something by trolley; to keep the position of idling gear	1.5 ~ 3.0

计算单台升降机的当量载荷W,

Calculate equivalent load of single Jack,

$$W = \frac{W_s}{\text{连动台数} \times \text{连动系数 } f_d}$$

$$W = \frac{W_s}{\text{Number} \times \text{Linkage factor } (f_d)}$$

连动系数 Linkage factor(f_d):

连动台数 Number of linkage jack	1	2	3	4	5~8
连动系数 Linkage factor	1	0.95	0.9	0.85	0.8

确定升降机型号:

Temporarily determine Jack type:

充分考虑载重, 速度, 行程, 效率, 驱动源后暂时选定型号

Temporarily determine Jack type after taking full consideration of load, speed, journey, efficiency and drive source.

根据使用行程、环境条件、输出顶端的联接方式, 确定升降机的整体型号。

Determine JW type according to service journey, ambient conditions, connection mode of end-fittings.

输入功率校核:

Verify input power

负载所需输入功率与许容最大输入功率相比较
如果超过请提高型号或降低丝杆轴转速再计算。

If required input power under load exceeds permissible maximum input power, please select larger type or lower the speed of screw rotation.

负载所需输入功率计算 Calculation of required input power under load :

所需输入轴转速 Required rotation speed of input shaft	n ₁ (r/min)	$n_1 = \frac{V}{L_i} \times i$
所需输入轴扭矩 Required torque of input shaft	T ₁ (N · m)	$T_1 = \frac{W \times L_i}{2 \pi \times i \times \eta} + T_0$
所需输入功率 Required input power	P ₁ (kW)	$P_1 = \frac{T_1 \times n_1}{9550}$

V: 升降机丝杆轴(活动螺母)升降速度 mm/min L_i: 丝杆螺距 (mm)
i: 减速比 W: 单台升降机当量载荷 (N) π: 圆周率
η: 升降机的综合效率 T₀: 空载扭矩 (N·m)
(L_i、i、η、T₀参照基本参数表)

V: linear speed of screw mm/min L: Pitch of screw (m)
i: ratio W: equivalent load of single jack π: pi
η: Integrated efficiency T₀: No-load torque (Nm)
(L_i、i、η、T₀ refer to basic parameter table)

丝杆稳定性校核

Verify the stability of screw:

当丝杆承受轴向压缩载荷时, 请对其进行稳定性校核, 如超过其临界载荷值请提高型号后再计算。

Please verify the stability of screw under axial load, larger type should be used when load exceed the critical load.

升降机丝杆临界稳定载荷通过以下公式计算:

The formula to calculate the critical load as follows,

$P_{CR} = f_m \times \left(\frac{d^2}{L_a}\right)^2$	确保 ensure	$P_{CR} > W \times SF \quad (SF = 4)$
--	--------------	---------------------------------------

P_{CR}: 临界载荷 (N)
d: 丝杆底径mm(参照基本参数表)
f_m: 支撑系数
L_a: 作用点间距离mm
W: 单台升降机当量载荷 (N)
SF: 安全系数 (一般SF=4)

P_{CR}: Critical load (N)
d: small diameter of screw end (mm) (refer to basic parameter table)
f_m: support factor
L_a: distance between load-supporting point and mounting point as drawing.
W: equivalent load of single Jack (N)
SF: safety factor (SF=4 as usual)

丝杆轴稳定性校验时，La (La值计算根据各型号尺寸) 与fm (支撑系数) 选取如下：

Verifying the stability of screw, the values of La and fm as follows,

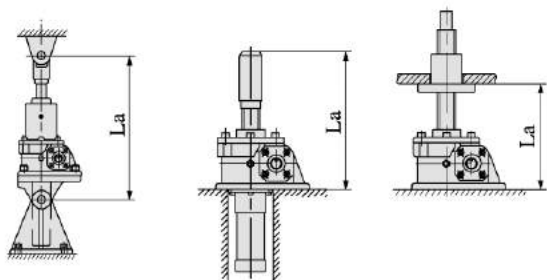

两端支撑 $f_m=10 \times 10^4$
support at both ends $f_m=10 \times 10^4$

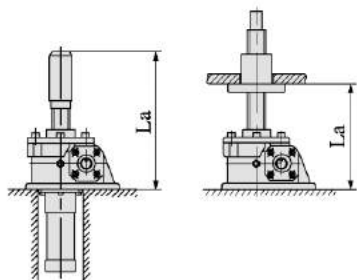

底座固定轴端自由 $f_m=2.5 \times 10^4$
Foot-mounted & movable shaft end $f_m=2.5 \times 10^4$

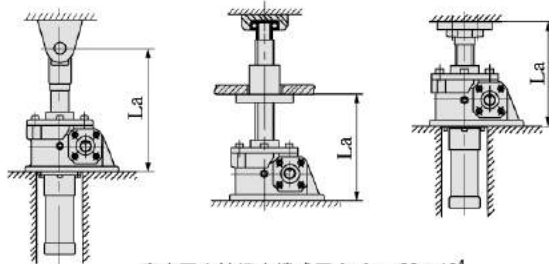

底座固定轴端支撑或固定 $f_m=20 \times 10^4$
Foot-mounted & shaft end supporting or fixed $f_m=20 \times 10^4$

临界转速校核

如为活动螺母选型时，请务必将丝杆轴转速控制在临界转速以下，若超出临界转速，请提高型号再计算。

Verifying critical rotation speed:

Using traveling nut, the rotation speed of screw must be lower than critical speed, if no, please select larger type and calculate again.

$$n_c = \frac{96 \times f_n \times d \times 10^6}{L_b^2}$$

$$n_s = \frac{n_1}{i}$$

n_c : 临界转速 r/min

n_s : 丝杆转速 r/min

d : 丝杆底径 mm(参照基本参数表)

n_1 : 输入速度 r/min

f_n : 长度系数

i : 减速比

L_b : 支撑间距离 mm

n_c : Permissible rotation speed of screw

n_s : Rotational speed of screw

d : Small diameter of screw (refer to basic parameter table)

n_1 : Rotational speed of input shaft

f_n : Length factor

i : ratio

L_b : Distance between both supporting face

丝杆轴转速校验时，Lb (Lb值计算根据各型号尺寸) 与 fn (长度系数) 选取如下：

Verifying the rotation speed of screw, the values of Lb and fn as follows,

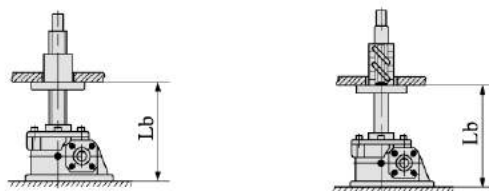

轴端自由 $f_n=0.36$
Movable shaft end $f_n=0.36$

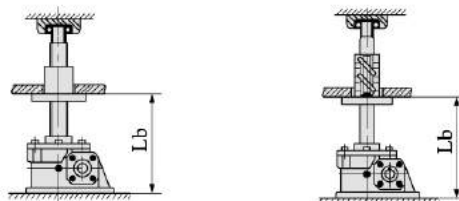

轴端支撑 $f_n=1.56$
Shaft end supporting $f_n=1.56$

请确保: $n_c > n_s$

Ensure: $n_c > n_s$

计算举例: JWM200UR-H1200PI在输入转速为1200r/min, 轴端支撑下运转, 根据外形尺寸与传动能力表查得:

Example for calculation:

Take JWM200UR-H1200PI as example, $n_1=1200$ r/min, connecting mode of top-end : I, we can know $d=49.3$, $L_b=1437$ referring to dimension and transmission capacity table.

$d=49.3$ $L_b=1437$

$$n_s = \frac{n_1}{i} = \frac{1200}{8} = 150 \text{r/min}$$

$$n_c = \frac{96 \times f_n \times d \times 10^6}{L_b^2} = \frac{96 \times 1.56 \times 49.3 \times 10^6}{(1437)^2} = 3575 \text{r/min}$$

$$n_c = 3575 \text{r/min} > n_s = 150 \text{r/min} \dots \dots \text{ok.}$$



当有横向载荷时，请外加导向器。

When there is radial load, please add guiding device.

JWM 许用横向载荷 Permitted radial load $F_r(N)$:

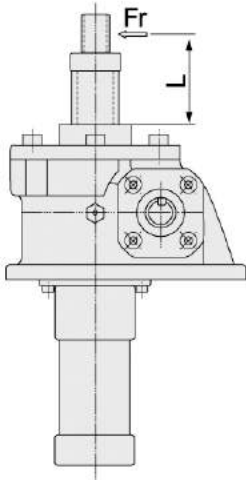

$F_r(N)$ / Type / L (mm)	010	025	050	100	150	200	300	500	750	1000
100	318	570	2500	4010	4610	8210	38200	85300	73500	186200
200	159	290	1250	2010	2300	4110	23000	50400	56800	145000
300	106	190	830	1340	1540	2740	15300	33600	46100	104700
400	79	140	620	1000	1150	2050	11400	25200	39300	78500
500	64	110	500	800	920	1640	9100	20200	33900	62800
600	53	100	420	670	770	1370	7600	16800	29900	52300
700	51	90	360	570	660	1170	6500	14400	26700	44800
800	48	90	310	500	580	1030	5700	12600	24100	39200
900	45	90	280	450	510	910	5000	11200	22000	34800
1000	42	90	250	400	460	820	4500	10100	20200	31300

JWB或JWM超过许用横向载荷时，请外加导向装置，举例如下：

When operating radial load exceeds critical radial load, please add guiding device, for example,

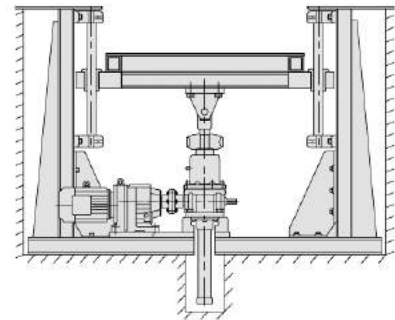
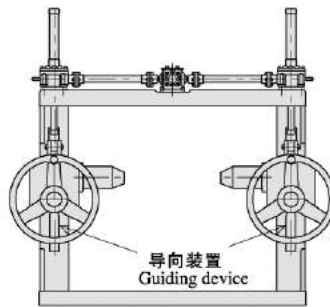
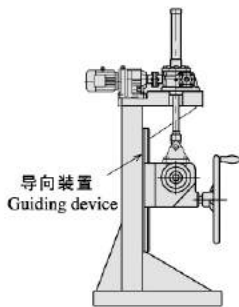

JW

当升降机传动配置为串联时(即同一轴线配置了两个或以上数量的升降机)如图须对各升降机输入轴端进行强度校核：

Please verify input torque of each Jack when several Jack are connected on the same input axial line as the following,

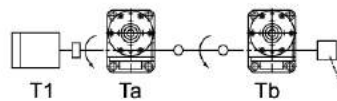

T_a : 为升降机a的所需输入扭矩

T_b : 为升降机b的所需输入扭矩

电机必需的扭矩 $T_1 = T_a + T_b <$ 升降机a的容许输入轴扭矩

T_a : Required torque of input shaft of jack a.

T_b : Required torque of input shaft of jack b.

Required torque of motor $T_1 = T_a + T_b <$

Permitted input torque of jack a.

升降机选择举例：

Jack selection example:

例题：4台连动押上用，结构如下图所示的4台连动模式，工厂内保持常温，有少许灰尘，有横向负荷在升降机侧面设置了导向器，安装状态采用底座固定，轴端采用一固定一支撑，电源为三相380V/50Hz，使用频率为2次/小时×8小时

Example: Four Jacks, linked as the following drawing, normal temperature, thin dust, radial load, with guiding devices on one side, foot-mounted, fixed the screw top-end, 380v/50Hz, service frequency: 2 times/hour, service time : 8 hours.

- 1.最大轴向载荷:88.2 KN/4台
- 2.升降速度:10mm/s (600mm/min)
- 3.使用行程:260mm

1. Maximum axial load ; 88.2KN/4 Jacks
2. Linear speed : 10mm/s (600mm/min)
3. Service journey : 260mm

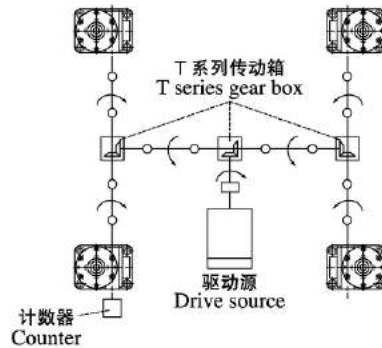

升降机型号确定

Determine Jack type,

- 1). 计算总机当量载荷 W_s (取被驱动设备系数为1.3)
 $W_s = W_{max} \cdot f_1 = 88200 \times 1.3 = 114660N$
- 2). 计算单台当量载荷 W

- 1) Calculate total equivalent load W_s
(Factor for driven machine is 1.3)
 $W_s = W_{max} \cdot f_1 = 88200 \times 1.3 = 114660N$
- 2) Calculate equivalent load of single jack:

$$W = \frac{114660}{4 \times 0.85} = 33724N$$

- 3). 暂定型号：
考虑速度、效率、驱动源、载重后暂定选择 JWB050USH (参照基本参数表)
- 4). 行程校核：
使用行程为260mm，充分考虑余量后选定行程为300mm (参照JWB050US尺寸表)
- 5). 输入功率校核：
(1)所需输入功率计算：

- 3) Temporarily determine type,
Temporarily determine JWB050USH according to speed, efficiency, drive and Load (refer to basic parameter table)
- 4) Verify journey:
Service journey is 260mm, determine journey should be 300 after considering surplus.
(Please refer to dimension sheet of JWB050US).
- 5) Check input power:
(1) Calculate required input power:

$$\textcircled{1} n_1 = \frac{V}{L_1} \times i = \frac{0.60}{0.010} \times 6 = 360r/min$$

$$\textcircled{2} T_1 = \frac{W \times L_1}{2\pi \times i \times \eta} + T_0$$

$$\textcircled{3} P_1 = \frac{T_1 \times n_1}{9550}$$

$$= \frac{33724 \times 0.010}{2 \times 3.14 \times 6 \times 0.64} + 1.37 = 15.4Nm$$

$$= \frac{15.4 \times 360}{9550} = 0.58kW$$

(2)参照基本参数表, $P_{max} = 2.2kW > P_1 \dots \dots OK$

(2) Refer to basic parameter table, $P_{max} = 2.2kW > P_1 \dots \dots OK$

6). 丝杆稳定性校核：
因为施加压缩载荷，根据传动能力表及外形尺寸图得出：

6) Verify the stability of screw
For under axial load, refer to transmission table and dimension for the following figures,

$$d=31.3 \quad L_a=604+33=637 \quad f_m=20 \times 10^4 \quad SF=4$$

$$P_{CR} = f_m \times \left(\frac{d}{L_a} \right)^2 = 20 \times 10^4 \times \left(\frac{31.3}{637} \right)^2 = 473073N$$

$$P_F = \frac{P_{CR}}{SF} = \frac{473073}{4} = 118268 > W = 33724$$

... ..OK

附件的确认:

Accessory confirmation:

C型安装:

Support (Mode C mounting):

支座安装广泛应用于开关装置、倾斜装置。如图:

Support-mounted mode widely apply to tilting equipment.

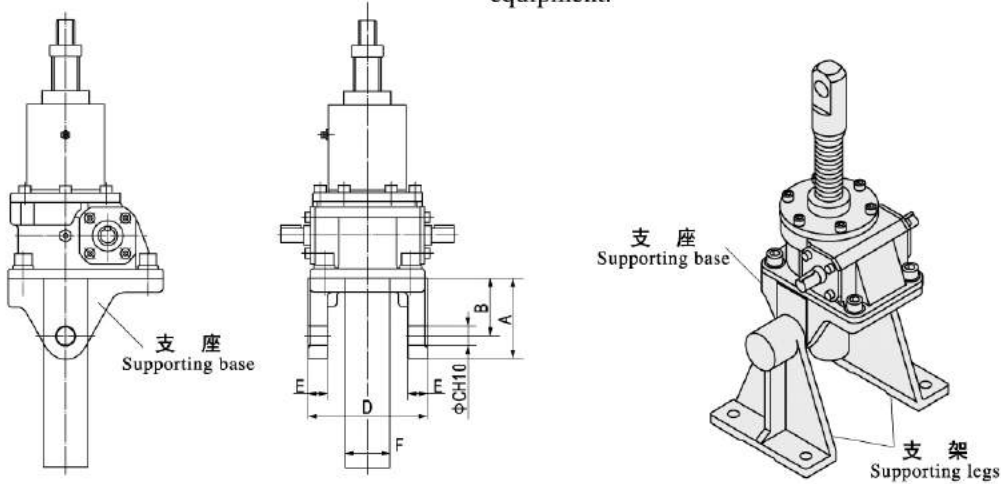

型号	A	B	C	D	E	F
010	75	60	15	86	15	35
025	100	75	20	115	20	45
050	105	75	25	158	25	58
100	145	100	40	201	30	76.3
150	155	105	50	224	44	76.3
200	173	110	63	244	50	89.1

JW

支架

Supporting legs:

支座与支架配合, 实现多方位升降。

Matching supporting base and legs realizes multi-angles lifting and lowering.

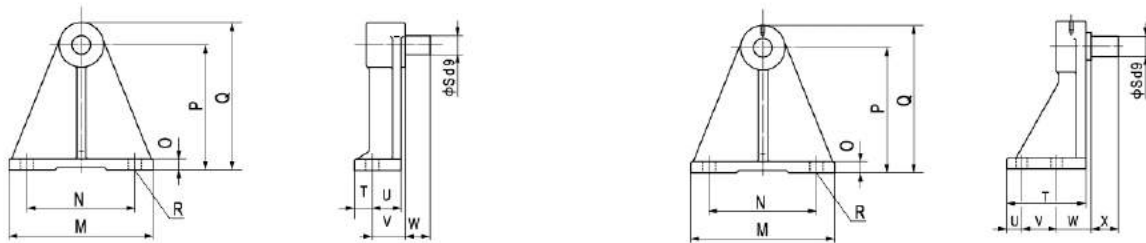

JW010-JW050

JW100-JW200

型号	M	N	O	P	Q	R	S	T	U	V	W	X
010	180	130	15	150	178	2-φ18	15	25	40	45	17	-
025	180	130	15	150	178	2-φ18	20	25	40	45	30	-
050	200	150	15	170	200	2-φ18	25	25	40	45	35	-
100	280	220	22	240	290	4-φ22	40	159	30	70	70	55
150	360	280	27	300	360	4-φ33	50	195	40	85	85	70
200	400	320	30	380	450	4-φ33	63	210	40	90	90	75

应用举例

Application example:

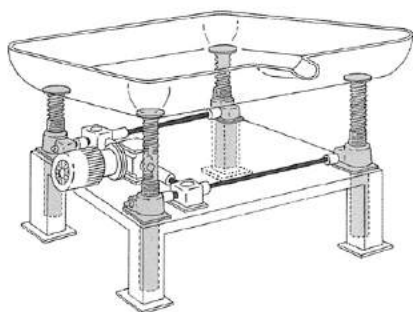

平台升降
Ascending and descending of flat slab

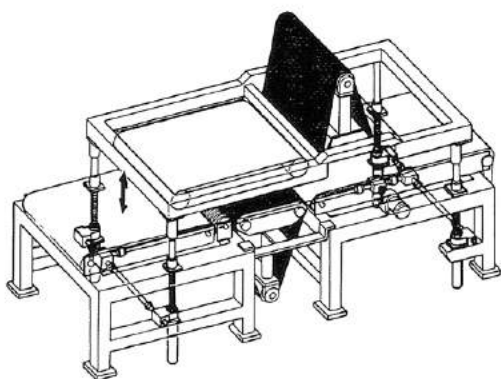
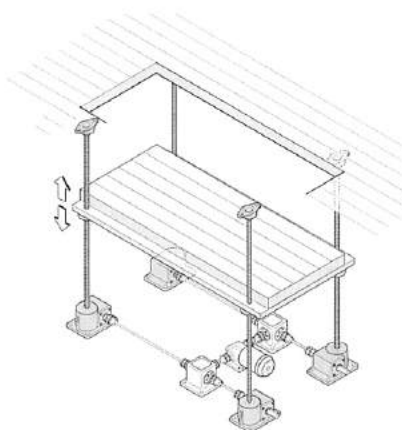

调整表面加工机的工作高度
Adjust operation height of surface machining tool

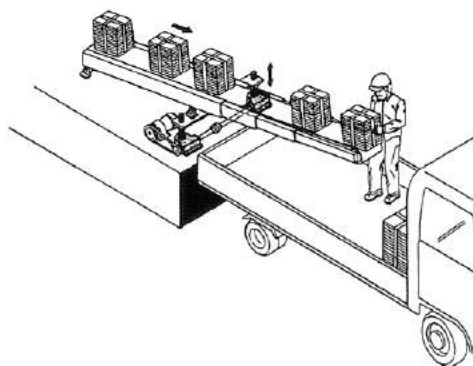

调整滑动传送带的倾斜程度
Adjust inclination pitch of conveyer apron

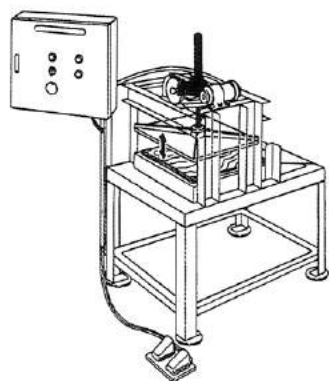

更改校正器的作业高度
Operation height of straightening machine

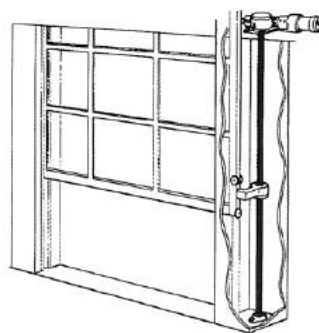

大型窗户（门）自动开关
Automatic switch on large windows (doors)

JW



JWB010

JWB010US

行程 (mm) Journey	U S				L	m (kg)
	X		X ⁽¹⁾			
	MIN	MAX	MIN	MAX		
100	162	262	212	312	194	6.7
200	162	362	212	412	294	7.0
300	162	462	252	552	434	7.4
400	162	562	252	652	534	7.6
500	162	662	287	787	669	8.0
600	162	762	287	887	769	8.2

JWB010DS

行程 (mm) Journey	D S				L	m (kg)
	X		X ⁽¹⁾			
	MIN	MAX	MIN	MAX		
100	25	125	75	175	194	6.7
200	25	225	75	275	294	7.0
300	25	325	115	415	434	7.4
400	25	425	115	515	534	7.6
500	25	525	150	650	669	8.0
600	25	625	150	750	769	8.2

JWB010UM

行程 (mm) Journey	U M				L	m (kg)
	X		X ⁽¹⁾			
	MIN	MAX	MIN	MAX		
100	162	262	212	312	194	7.5
200	162	362	212	412	294	8.2
300	162	462	252	552	434	9.1
400	162	562	252	652	534	9.8
500	162	662	287	787	669	11
600	162	762	287	887	769	12

JWB010DM

行程 (mm) Journey	D M				L	m (kg)
	X		X ⁽¹⁾			
	MIN	MAX	MIN	MAX		
100	25	125	75	175	194	7.5
200	25	225	75	275	294	8.2
300	25	325	115	415	434	9.1
400	25	425	115	515	534	9.8
500	25	525	150	650	669	11
600	25	625	150	750	769	12

J

B

I

M

JWB010UR

行程 (mm) Journey	U R				m (kg)
	X		Y	m	
	MIN	MAX	Y		
100	108	208	265	5.9	
200	108	308	365	6.1	
300	108	408	465	6.4	
400	108	508	565	6.6	
500	108	608	665	6.8	
600	108	708	765	7.0	

JWB010DR

行程 (mm) Journey	D R				m (kg)
	X		Y	m	
	MIN	MAX	Y		
100	69	169	179	5.9	
200	69	269	279	6.1	
300	69	369	379	6.4	
400	69	469	479	6.6	
500	69	569	579	6.8	
600	69	669	679	7.0	

注: X⁽¹⁾ 为加防尘罩时尺寸。

Note: "X⁽¹⁾" is the dimension of jack with dust hood.

JWB025

JWB025US

JWB025DS

行程 (mm) Journey	U S					
	X		X ⁽¹⁾		L	m (kg)
	MIN	MAX	MIN	MAX		
100	225	325	240	340	149	11
200	225	425	240	440	249	11
300	225	525	260	560	369	11
400	225	625	260	660	469	12
500	225	725	280	780	589	12
600	225	825	280	880	689	13
800	225	1025	300	1100	909	14

行程 (mm) Journey	D S					
	X		X ⁽¹⁾		L	m (kg)
	MIN	MAX	MIN	MAX		
100	42	142	57	157	156	11
200	42	242	57	257	256	11
300	42	342	77	377	376	11
400	42	442	77	477	476	12
500	42	542	97	597	596	12
600	42	642	97	697	696	13
800	42	842	117	917	916	14

JWB025UM

JWB025DM

行程 (mm) Journey	U M					
	X		X ⁽¹⁾		L	m (kg)
	MIN	MAX	MIN	MAX		
100	225	325	240	340	175	12
200	225	425	240	440	275	13
300	225	525	260	560	395	15
400	225	625	260	660	495	16
500	225	725	280	780	615	17
600	225	825	280	880	715	18
800	225	1025	300	1100	935	21

行程 (mm) Journey	D M					
	X		X ⁽¹⁾		L	m (kg)
	MIN	MAX	MIN	MAX		
100	42	142	57	157	182	12
200	42	242	57	257	282	13
300	42	342	77	377	402	15
400	42	442	77	477	502	16
500	42	542	97	597	622	17
600	42	642	97	697	722	18
800	42	842	117	917	942	21

J

B

I

M

JWB025UR

JWB025DR

行程 (mm) Journey	U R				L	m (kg)
	X		Y			
	MIN	MAX	MIN	MAX		
100	133	233	309	9.2		
200	133	333	409	9.5		
300	133	433	509	9.9		
400	133	533	609	11		
500	133	633	709	11		
600	133	733	809	11		
800	133	933	1009	12		

行程 (mm) Journey	D R				L	m (kg)
	X		Y			
	MIN	MAX	MIN	MAX		
100	108	208	219	9.2		
200	108	308	319	9.5		
300	108	408	419	9.9		
400	108	508	519	11		
500	108	608	619	11		
600	108	708	719	11		
800	108	808	819	12		

注: X⁽¹⁾ 为加防尘罩时尺寸。

Note: "X⁽¹⁾" is the dimension of jack with dust hood.



JWB050

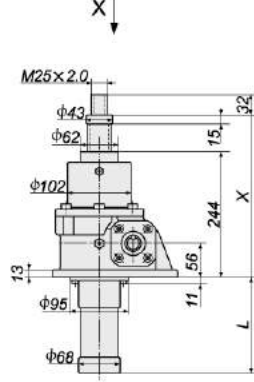
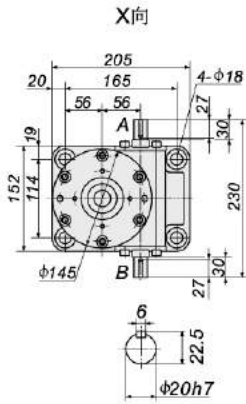

JWB050US

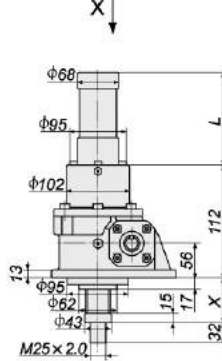

JWB050DS

行程 (mm) Journey	U S					
	X		X ⁽¹⁾		L	m (kg)
	MIN	MAX	MIN	MAX		
100	269	369	284	384	147	23
200	269	469	284	484	247	23
300	269	569	304	604	367	24
400	269	669	304	704	467	25
500	269	769	324	824	587	26
600	269	869	324	924	687	27
800	269	1069	344	1144	907	29
1000	269	1269	364	1364	1127	30

行程 (mm) Journey	D S					
	X		X ⁽¹⁾		L	m (kg)
	MIN	MAX	MIN	MAX		
100	42	142	57	157	147	23
200	42	242	57	257	247	23
300	42	342	77	377	367	24
400	42	442	77	477	467	25
500	42	542	97	597	587	26
600	42	642	97	697	687	27
800	42	842	117	917	907	29
1000	42	1042	137	1137	1127	30

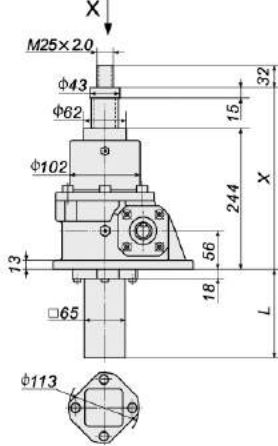
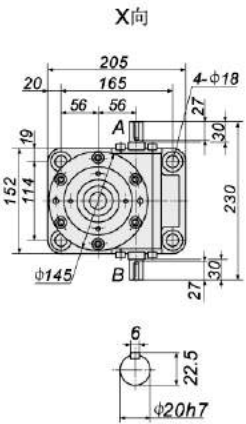

JWB050UM

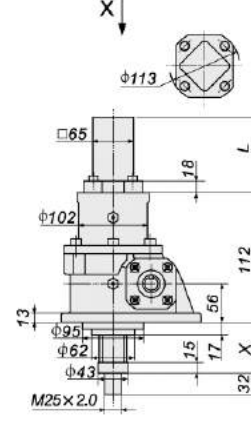

JWB050DM

行程 (mm) Journey	U M					
	X		X ⁽¹⁾		L	m (kg)
	MIN	MAX	MIN	MAX		
100	269	369	284	384	175	25
200	269	469	284	484	275	27
300	269	569	304	604	395	29
400	269	669	304	704	495	31
500	269	769	324	824	615	33
600	269	869	324	924	715	35
800	269	1069	344	1144	935	39
1000	269	1269	364	1364	1155	43

行程 (mm) Journey	D M					
	X		X ⁽¹⁾		L	m (kg)
	MIN	MAX	MIN	MAX		
100	42	142	57	157	175	25
200	42	242	57	257	275	27
300	42	342	77	377	395	29
400	42	442	77	477	495	31
500	42	542	97	597	615	33
600	42	642	97	697	715	35
800	42	842	117	917	935	39
1000	42	1042	137	1137	1155	43

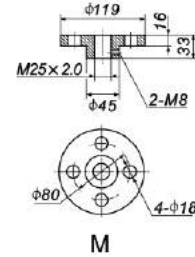
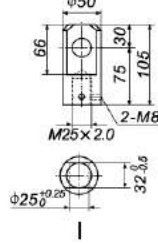
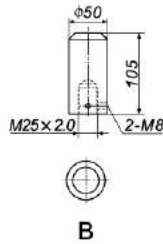
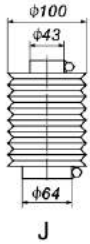

J

B

I

M

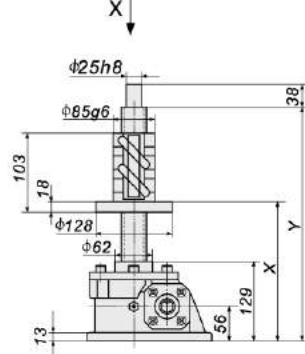
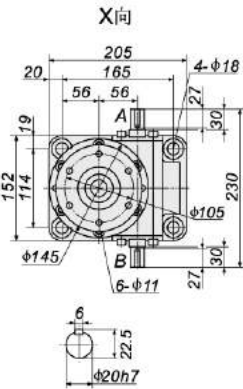

JWB050UR

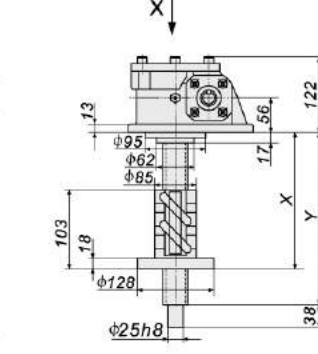

JWB050DR

行程 (mm) Journey	U R				
	X		Y	L	m (kg)
	MIN	MAX			
100	157	257	354	21	21
200	157	357	454	22	22
300	157	457	554	22	22
400	157	557	654	23	23
500	157	657	754	24	24
600	157	757	854	24	24
800	157	957	1054	26	26
1000	157	1157	1254	27	27

行程 (mm) Journey	D R				
	X		Y	L	m (kg)
	MIN	MAX			
100	130	230	242	21	21
200	130	330	342	22	22
300	130	430	442	22	22
400	130	530	542	23	23
500	130	630	642	24	24
600	130	730	742	24	24
800	130	930	942	26	26
1000	130	1130	1142	27	27

注: X⁽¹⁾ 为加防尘罩时尺寸。

Note: "X⁽¹⁾" is the dimension of jack with dust hood.



JWB100

行程 (mm) Journey	U S				
	X		X ⁽¹⁾		L
	MIN	MAX	MIN	MAX	
100	302	402	312	412	151
200	302	502	312	512	252
300	302	602	327	627	366
400	302	702	327	727	466
500	302	802	352	852	591
600	302	902	352	952	691
800	302	1102	367	1167	906
1000	302	1302	377	1377	1116
1200	302	1502	402	1602	1341

行程 (mm) Journey	D S				
	X		X ⁽¹⁾		L
	MIN	MAX	MIN	MAX	
100	42	142	52	152	151
200	42	242	52	252	252
300	42	342	67	367	366
400	42	442	67	467	466
500	42	542	92	592	591
600	42	642	92	692	691
800	42	842	107	907	906
1000	42	1042	117	1117	1116
1200	42	1242	142	1342	1341

行程 (mm) Journey	U M				
	X		X ⁽¹⁾		L
	MIN	MAX	MIN	MAX	
100	302	402	312	412	192
200	302	502	312	512	292
300	302	602	327	627	407
400	302	702	327	727	507
500	302	802	352	852	632
600	302	902	352	952	732
800	302	1102	367	1167	947
1000	302	1302	377	1377	1157
1200	302	1502	402	1602	1382

行程 (mm) Journey	D M				
	X		X ⁽¹⁾		L
	MIN	MAX	MIN	MAX	
100	42	142	52	152	192
200	42	242	52	252	292
300	42	342	67	367	407
400	42	442	67	467	507
500	42	542	92	592	632
600	42	642	92	692	732
800	42	842	107	907	947
1000	42	1042	117	1117	1157
1200	42	1242	142	1342	1382

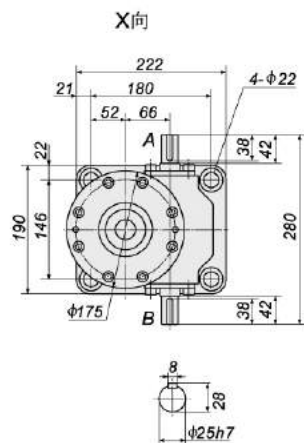

JWB100US

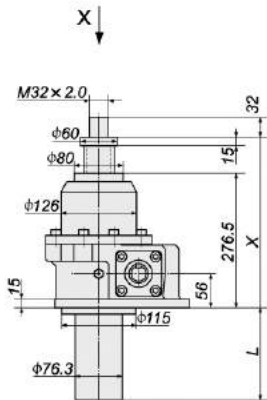

JWB100DS

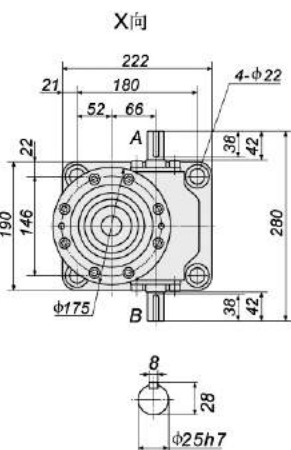
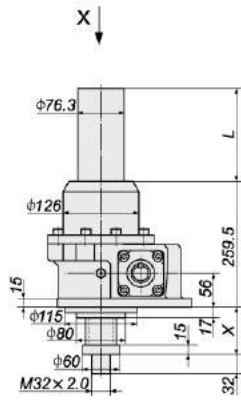

JWB100UM

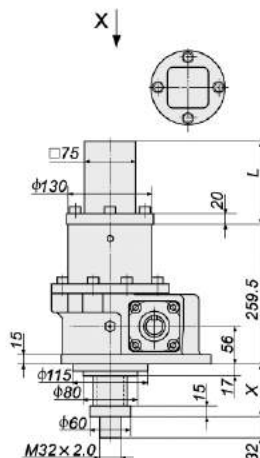
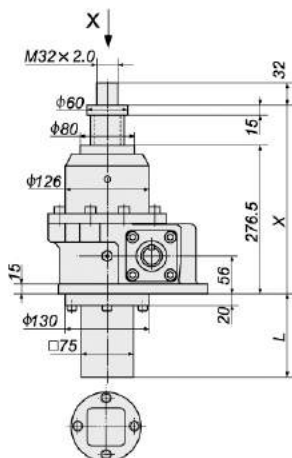

JWB100DM



J

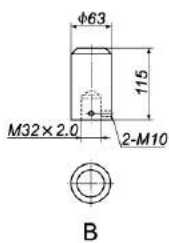

B

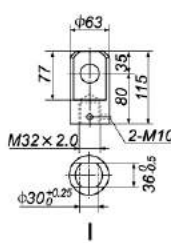

I

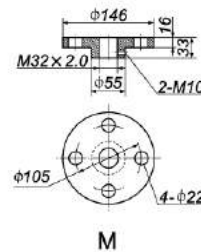

M

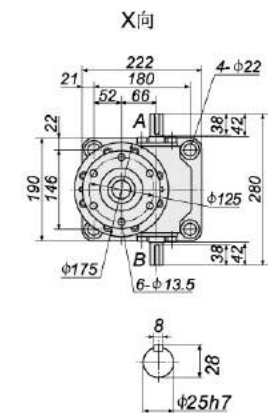

JWB100UR

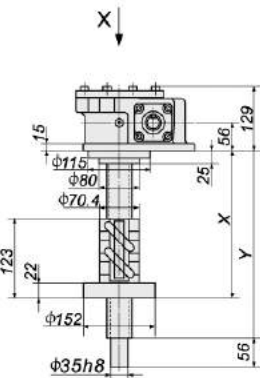
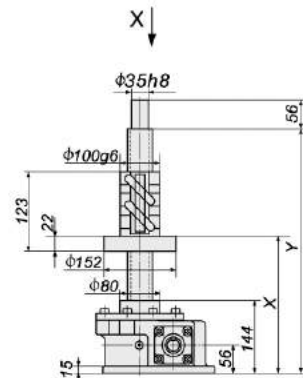

JWB100DR

行程 (mm) Journey	U R				
	X		Y		m (kg)
	MIN	MAX	MIN	MAX	
100	176	276	387	31	
200	176	376	487	32	
300	176	476	587	33	
400	176	576	687	34	
500	176	676	787	35	
600	176	776	887	36	
800	176	976	1087	39	
1000	176	1176	1287	41	
1200	176	1376	1487	43	

行程 (mm) Journey	D R				
	X		Y		m (kg)
	MIN	MAX	MIN	MAX	
100	158	258	268	31	
200	158	358	368	32	
300	158	458	468	33	
400	158	558	568	34	
500	158	658	668	35	
600	158	758	768	36	
800	158	958	968	39	
1000	158	1158	1168	41	
1200	158	1358	1368	43	

注: X⁽¹⁾ 为加防尘罩时尺寸。

Note: "X⁽¹⁾" is the dimension of jack with dust hood.



JWB150

JWB150US

JWB150DS

行程 (mm) Journey	U S					
	X		X ⁽¹⁾		L	m (kg)
	MIN	MAX	MIN	MAX		
100	342	442	352	452	151	46
200	342	542	352	552	252	48
300	342	642	367	667	366	51
400	342	742	367	767	466	54
500	342	842	392	892	591	57
600	342	942	392	992	691	60
800	342	1142	407	1207	906	65
1000	342	1342	417	1417	1116	70
1200	342	1542	442	1642	1341	76

JWB150UM

JWB150DM

行程 (mm) Journey	U M					
	X		X ⁽¹⁾		L	m (kg)
	MIN	MAX	MIN	MAX		
100	342	442	352	452	221	52
200	342	542	352	552	321	55
300	342	642	367	667	436	59
400	342	742	367	767	536	62
500	342	842	392	892	661	66
600	342	942	392	992	781	69
800	342	1142	407	1207	976	75
1000	342	1342	417	1417	1186	82
1200	342	1542	442	1642	1411	89

J

B

I

M

JWB150UR

JWB150DR

行程 (mm) Journey	U R					
	X		Y		L	m (kg)
	MIN	MAX	MIN	MAX		
100	201	301	412	41	41	
200	201	401	512	42	42	
300	201	501	612	43	43	
400	201	601	712	45	45	
500	201	701	812	46	46	
600	201	801	912	47	47	
800	201	1001	1112	50	50	
1000	201	1201	1312	53	53	
1200	201	1401	1512	55	55	

行程 (mm) Journey	D R					
	X		Y		L	m (kg)
	MIN	MAX	MIN	MAX		
100	161	261	272	41	41	
200	161	361	372	42	42	
300	161	461	472	43	43	
400	161	561	572	45	45	
500	161	661	672	46	46	
600	161	761	772	47	47	
800	161	961	972	50	50	
1000	161	1161	1172	53	53	
1200	161	1361	1372	55	55	

注: X⁽¹⁾ 为加防尘罩时尺寸。

Note: "X⁽¹⁾" is the dimension of jack with dust hood.



JWB200

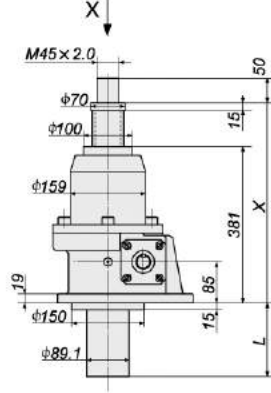
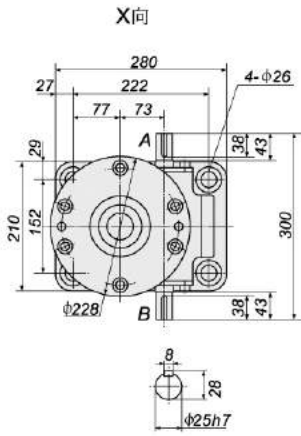

JWB200US

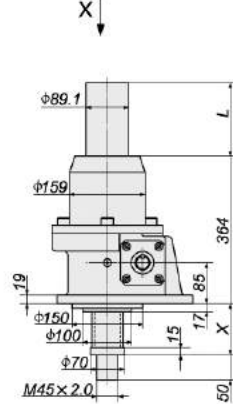

JWB200DS

行程 (mm) Journey	U S					
	X		X ⁽¹⁾		L	m (kg)
	MIN	MAX	MIN	MAX		
100	406	506	416	516	151	65
200	406	606	416	616	252	68
300	406	706	431	731	366	72
400	406	806	431	831	466	76
500	406	906	456	956	591	80
600	406	1006	456	1056	691	83
800	406	1206	471	1271	906	90
1000	406	1406	481	1481	1116	97
1200	406	1606	506	1706	1357	105

行程 (mm) Journey	D S					
	X		X ⁽¹⁾		L	m (kg)
	MIN	MAX	MIN	MAX		
100	42	142	52	152	151	65
200	42	242	52	252	252	68
300	42	342	67	367	366	72
400	42	442	67	467	466	76
500	42	542	92	592	591	80
600	42	642	92	692	691	83
800	42	842	107	907	906	90
1000	42	1042	117	1117	1116	97
1200	42	1242	142	1342	1357	105

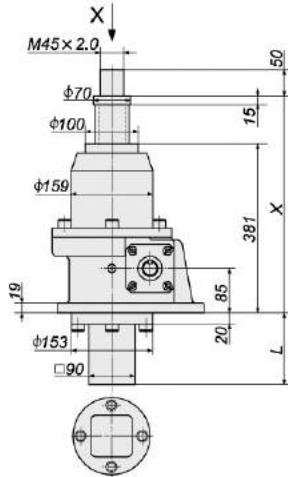
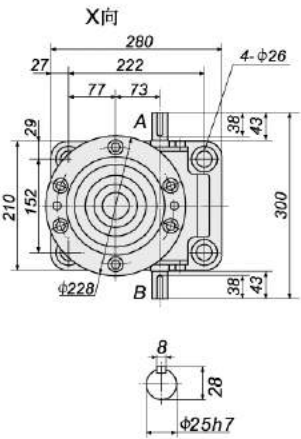

JWB200UM

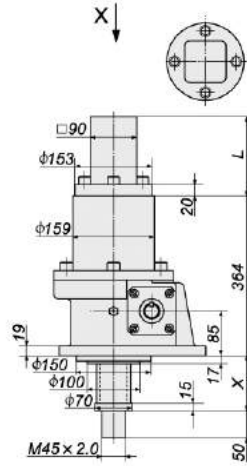

JWB200DM

行程 (mm) Journey	U M					
	X		X ⁽¹⁾		L	m (kg)
	MIN	MAX	MIN	MAX		
100	406	506	416	516	230	72
200	406	606	416	616	330	76
300	406	706	431	731	445	80
400	406	806	431	831	545	84
500	406	906	456	956	670	89
600	406	1006	456	1056	770	93
800	406	1206	471	1271	985	102
1000	406	1406	481	1481	1195	110
1200	406	1606	506	1706	1420	119

行程 (mm) Journey	D M					
	X		X ⁽¹⁾		L	m (kg)
	MIN	MAX	MIN	MAX		
100	42	142	52	152	230	72
200	42	242	52	252	330	76
300	42	342	67	367	445	80
400	42	442	67	467	545	84
500	42	542	92	592	670	89
600	42	642	92	692	770	93
800	42	842	107	907	985	102
1000	42	1042	117	1117	1195	110
1200	42	1242	142	1342	1420	119

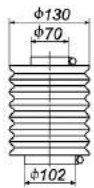

J



B

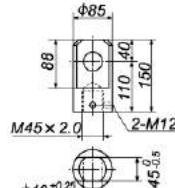

I

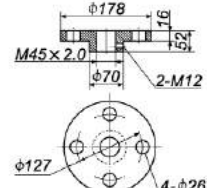

M

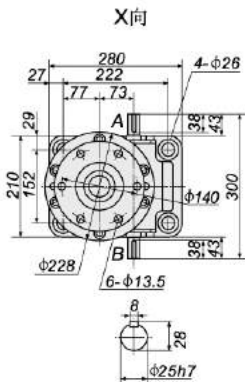

JWB200UR

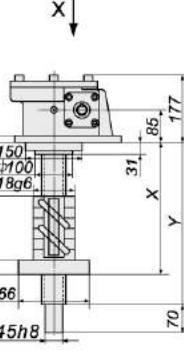
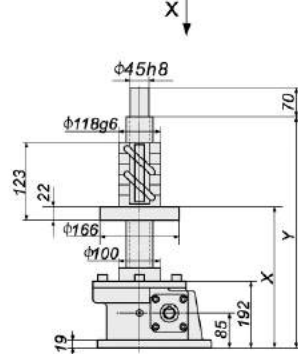

JWB200DR

行程 (mm) Journey	U R				
	X		Y		m (kg)
	MIN	MAX	MIN	MAX	
100	224	324	435	56	
200	224	424	535	58	
300	224	524	635	60	
400	224	624	735	62	
500	224	724	835	65	
600	224	824	935	67	
800	224	1024	1135	71	
1000	224	1224	1335	76	
1200	224	1424	1535	80	

行程 (mm) Journey	D R				
	X		Y		m (kg)
	MIN	MAX	MIN	MAX	
100	164	264	274	56	
200	164	364	374	58	
300	164	464	474	60	
400	164	564	574	62	
500	164	664	674	65	
600	164	764	774	67	
800	164	964	974	71	
1000	164	1164	1174	76	
1200	164	1364	1374	80	

注: X⁽¹⁾ 为加防尘罩时尺寸。

Note: "X⁽¹⁾" is the dimension of jack with dust hood.



JWB300

行程 (mm) Journey	U S					D S					m (kg)
	X		X ⁽¹⁾		L	X		X ⁽¹⁾		L	
	MIN	MAX	MIN	MAX		MIN	MAX	MIN	MAX		
100	480	580	490	590	160	55	155	65	165	160	153
200	480	680	490	690	260	55	255	65	265	260	159
300	480	780	505	805	375	55	355	80	380	375	166
400	480	880	505	905	475	55	455	80	480	475	172
500	480	980	520	1020	590	55	555	95	595	590	178
600	480	1080	520	1120	690	55	655	95	695	690	184
800	480	1280	535	1335	905	55	855	110	910	905	197
1000	480	1480	555	1555	1125	55	1050	130	1130	1125	210
1200	480	1680	565	1765	1335	55	1255	140	1340	1335	223
1500	480	1980	590	2090	1660	55	1555	165	1665	1660	242

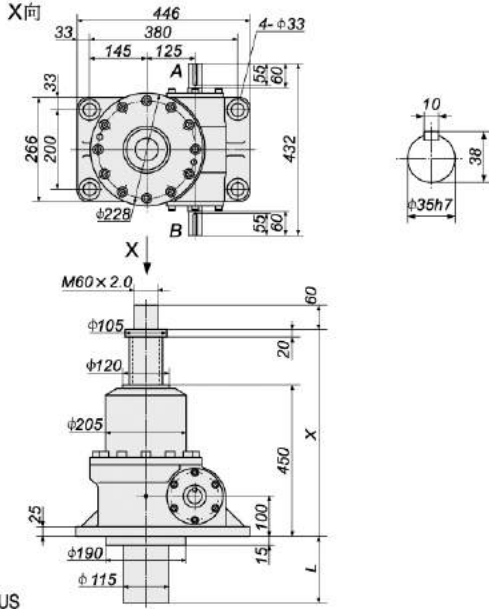

JWB300US

JWB500

行程 (mm) Journey	U S					D S					m (kg)
	X		X ⁽¹⁾		L	X		X ⁽¹⁾		L	
	MIN	MAX	MIN	MAX		MIN	MAX	MIN	MAX		
100	580	680	585	685	165	55	155	60	160	165	310
200	580	780	585	785	265	55	255	60	260	265	320
300	580	880	605	905	385	55	355	80	380	385	330
400	580	980	605	1005	485	55	455	80	480	485	340
500	580	1080	615	1115	595	55	555	90	590	595	350
600	580	1180	615	1215	695	55	655	90	690	695	359
800	580	1380	630	1430	910	55	855	105	905	910	378
1000	580	1580	645	1645	1125	55	1050	120	1120	1125	398
1200	580	1780	655	1855	1335	55	1255	130	1330	1335	417
1500	580	2080	675	2175	1665	55	1555	150	1650	1665	446

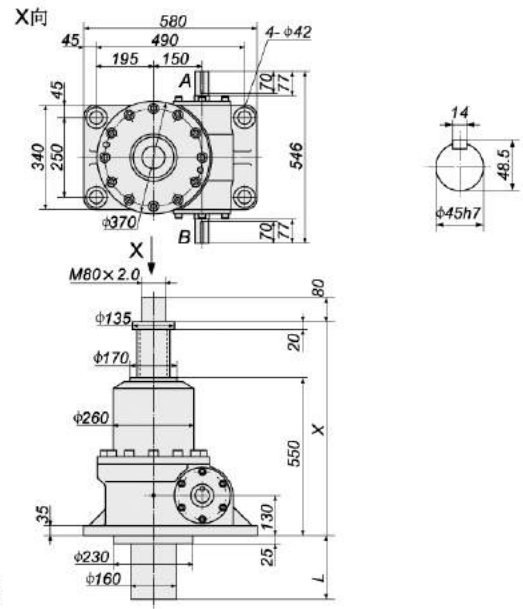

JWB500US

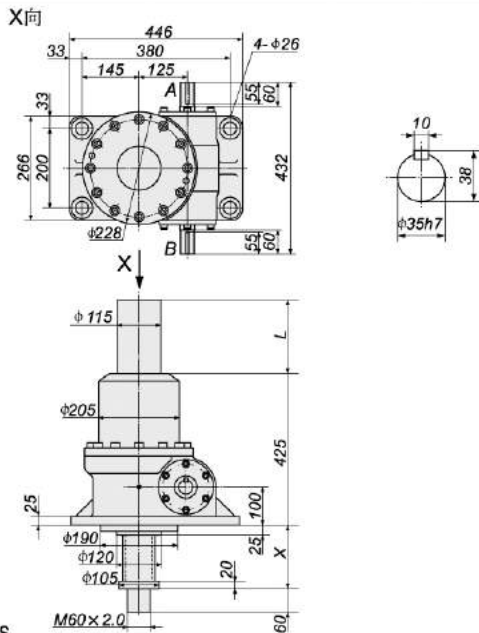

JWB300DS

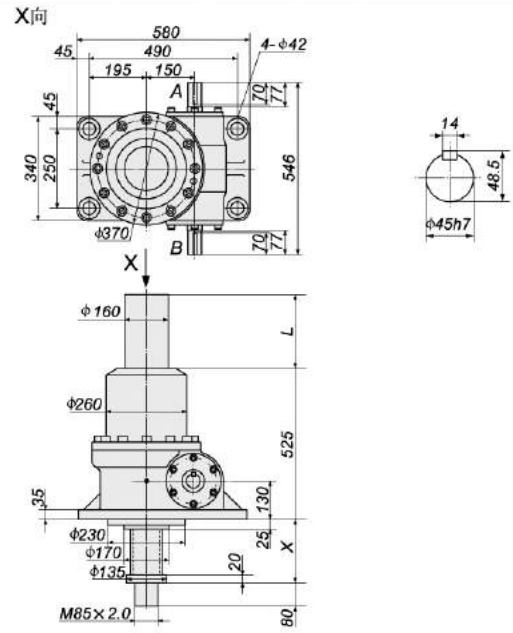

JWB500DS

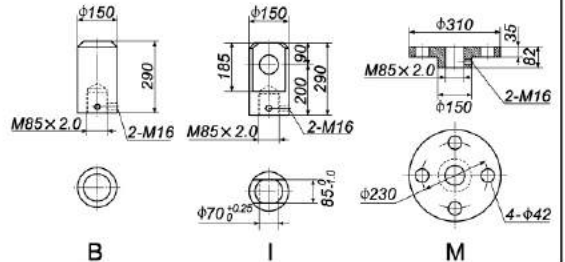
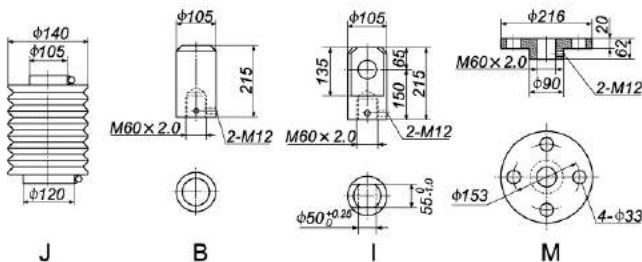

注: X⁽¹⁾ 为加防尘罩时尺寸。

Note: "X⁽¹⁾" is the dimension of jack with dust hood.



厂址：山东省德州高新技术开发区蒙阴路2758号
营销热线：0534-2796998 2787998 2783998 2763998
传真：0534-8310998
E-mail：china@ludccd.com
网址：www.ludccd.com