

## JWM系列梯形丝杆升降机选型手册

## JW丝杆升降机概述

### JWM型（梯形丝杆型）

#### 低速、低频率

JWM型（梯形丝杆型）适用于低速、低频率的场合，主要构成部件为：精密梯形丝杆副与高精度蜗轮蜗杆副。

- 1) 价格经济、结构紧凑、操作简单、保养方便。
- 2) 低速、低频率：  
主要用于大负荷、低速与无需频繁工作的场所。
- 3) 保持载重：梯形丝杆具有自动锁定功能，既使没有制动装置也可保持载重。

\*在受到较大振动，冲击载荷时，可能会使自锁功能失效，此时请外加制动装置。



JWM（梯形丝杆类型）基本参数一览表

型号 Type			JWM010	JWM025	JWM050	JWM100	JWM150	JWM200	JWM300	JWM500	JWM750	JWM1000
最大载荷 Maximal load	(kN)		9.80	24.5	49.0	98.0	147	196	294	490	735	980
丝杆外径 Outer diameter of screw	(mm)		20	26	40	50	55	65	85	120	130	150
丝杆底径 Small diameter of screw	d (mm)		14.8	19.7	30.5	38.4	43.4	49.3	67	102	112	127
丝杆螺距 Pitch of screw	L1 (mm)		4	5	8	10	10	12	16	16	16	20
减速比 Ratio i	H速度 Speed		5	6	6	8	8	8	10 <sup>2/3</sup>	10 <sup>2/3</sup>	10 <sup>2/3</sup>	12
	L速度 Speed		20	24	24	24	24	24	32	32	32	36
综合效率 % Integrated efficiency η	H速度 Speed		21	21	22	22	20	20	19	15	13	13
	L速度 Speed		12	12	14	15	14	13	11	10	8	8
容许输入最大功率 (kW) Permissible output maximal power	H速度 Speed		0.49	1.0	2.0	2.8	3.1	5.0	8.4	13.4	14.4	21.4
	L速度 Speed		0.36	0.46	0.63	1.4	2.2	3.2	4.6	5.7	7.2	9.4
空载扭矩 No-load torque	T <sub>0</sub> (N·m)		0.29	0.62	1.4	2.0	2.6	3.9	9.8	19.6	29.4	39.2
容许输入轴扭矩* Permissible torque of input shaft (N·m)			19.6	49.0	153.9	292.0	292.0	292.0	735.0	1372.0	1764.0	2450.0
最大载荷时所需输入轴扭矩** Required torque of input shaft at maximal load (N·m)	H速度 Speed		6.2	16.1	48.7	90.7	149.0	238.1	400.1	856.0	1380.5	2040.9
	L速度 Speed		2.9	7.4	20.0	45.3	72.3	124.0	244.0	453.3	761.3	1278.3
输入轴每回转一圈丝杆(活动螺母)轴向位移量 Axial journey of screw, when input shaft rotate a circle. (mm)	H速度 Speed		0.80	0.83	1.33	1.25	1.25	1.50	1.50	1.50	1.50	1.67
	L速度 Speed		0.20	0.21	0.33	0.42	0.42	0.50	0.50	0.50	0.50	0.56
最大载荷时容许输入轴回转速度 Permissible rotational speed of screw shaft at maximal load (rpm)	H速度 Speed		750	600	400	300	200	200	200	150	100	100
	L速度 Speed		1200	600	300	300	290	250	180	120	90	70
最大载荷时丝杆回转扭矩 (N·m) Rotational torque of screw at maximal load			20.1	65.1	201.5	503.6	813.2	1287.7	2531.9	5551.3	8921.8	13878.3

\* 减速机输入轴的容许扭矩。(连动运转时请确认)  
\*\* 包括无负荷空转扭矩的数值。

## JW series screw jack overview:

### JWM (Trapezoid screw)

#### LOW SPEED LOW FREQUENCY

JWM (trapezoidal screw) is suitable for low speed and low frequency.

Main components: Precision trapezoid screw pair and high precision worm-gears pair.

- 1) Economical:  
Compact design, easy operation, convenient maintenance.
- 2) Low speed, low frequency:  
Be suitable for heavy load, low speed, low service frequency.
- 3) Self-lock  
Trapezoid screw has self-lock function, it can hold up load without braking device when screw stops traveling.

Braking device equipped for self-lock will be of malfunction accidentally when large jolt & impact load occur.

JWM (Trapezoid screw) basic parameter table:



应用示例：  
两台联动：

Application example:  
Two gear boxes linking:

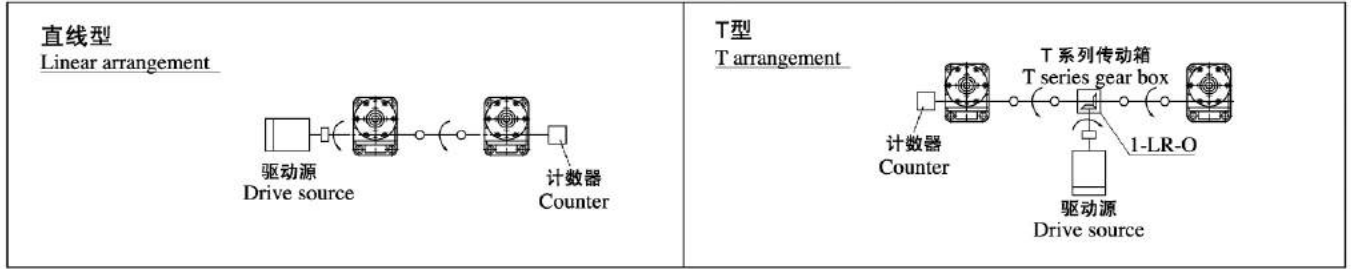

四台联动：

Four gear boxes linking:

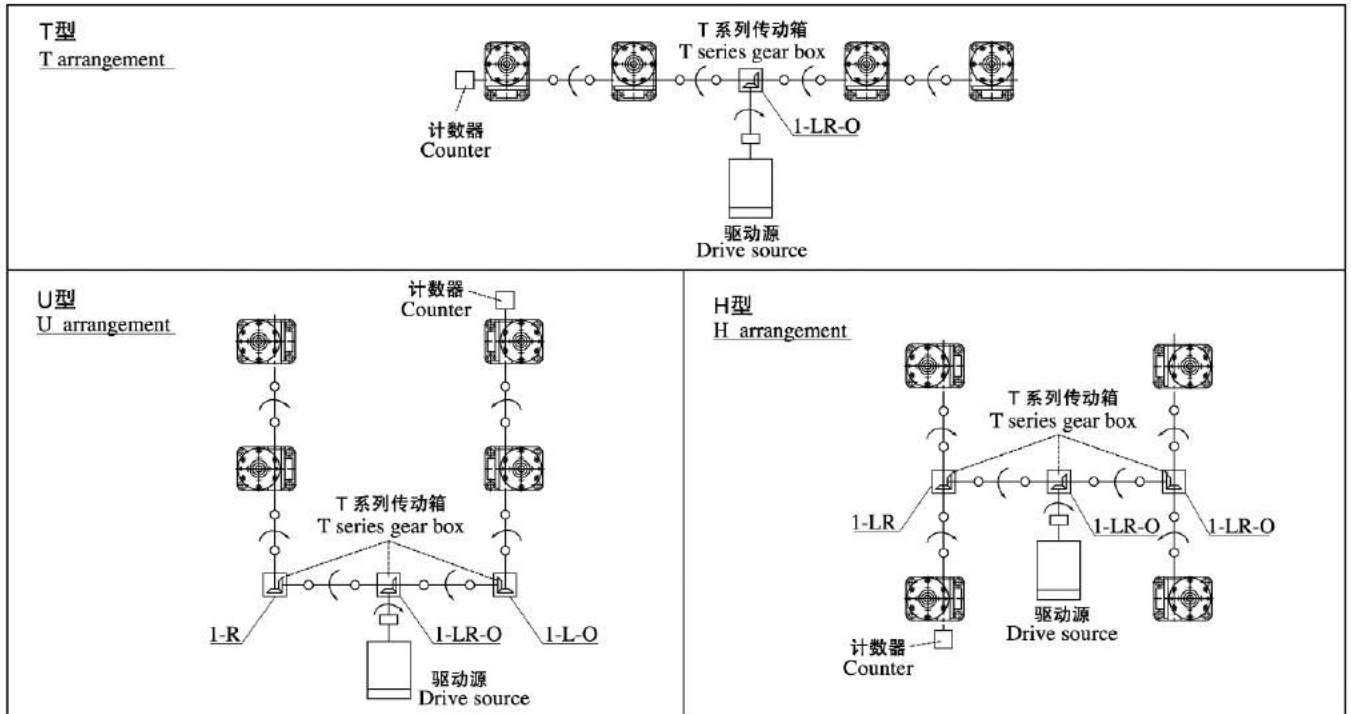

八台联动：

Eight gear boxes linking:

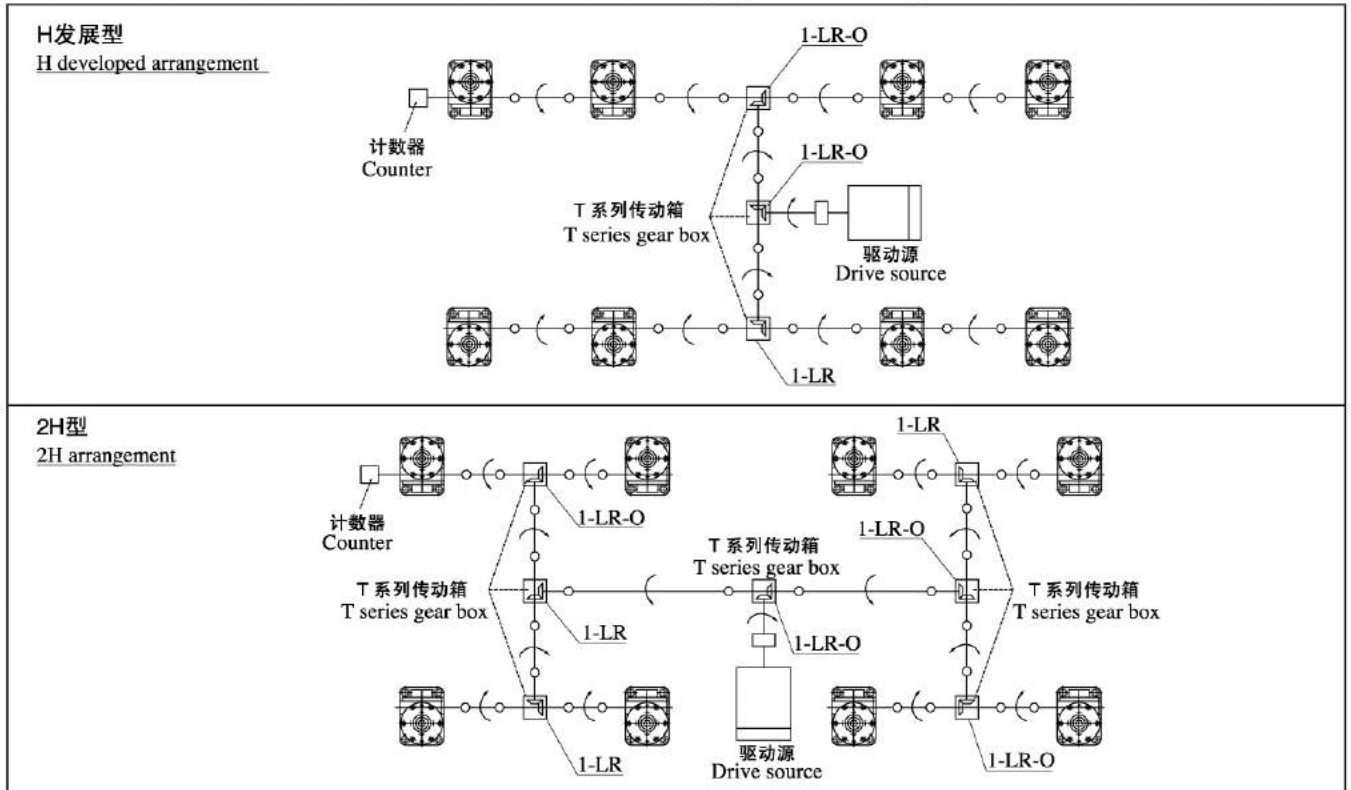

型号表示方法举例：

基本形式和止旋构造升降机的型号表示方法：

Illustration of types:

Plain mode and Mode with anti-rotation device:

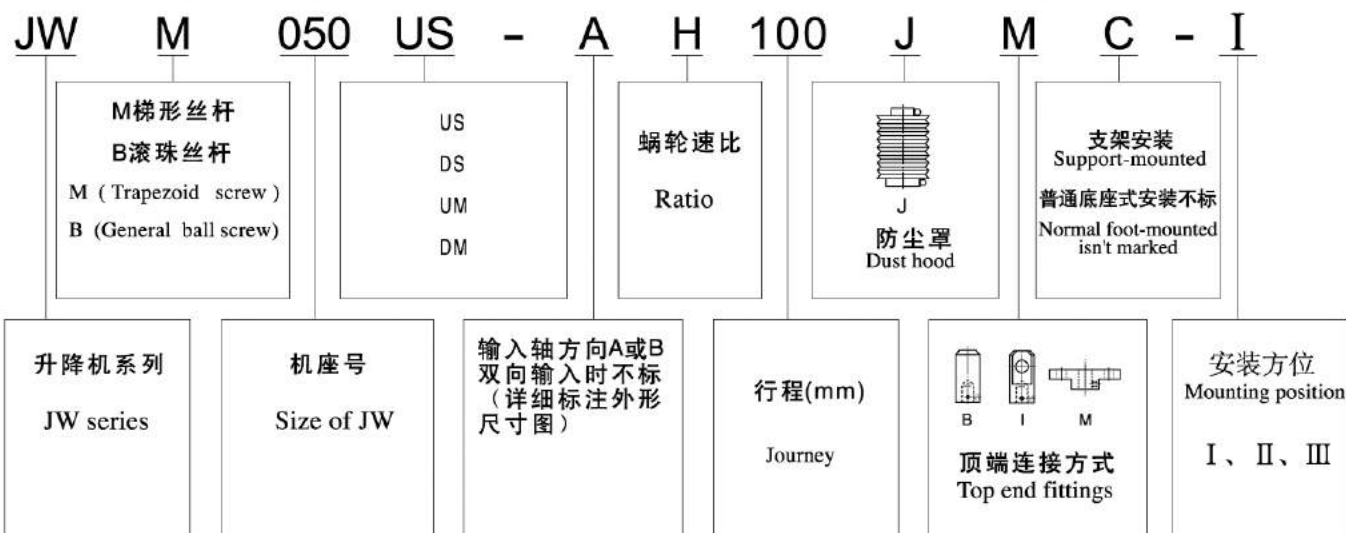

**基本形式 (US, DS)**

螺母转动, 丝杆上下移动并伴随附加的旋转运动, (如下图)

US: 押上 DS: 吊下

- \* 请根据载荷方向、安装方向来选择合适的升降机 (US或DS).
- \* 丝杆轴在升降时, 会产生旋转力, 所以必须做好防止旋转措施.

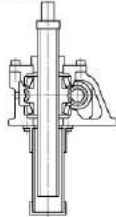

US

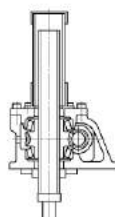

DS

**止旋构造 (UM, DM)**

UM: 押上 DM: 吊下

- \* 丝杆只能上下移动
- \* 请根据载荷方向、安装方向来选合适的升降机 (UM或DM)

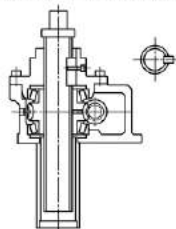

(JWM100-JWM200)  
UM

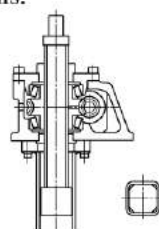

(JWM010-JWM050) (JWB010-JWB200)  
DM

**Plain mode (US, DS)**

Worm wheel rotating, threaded spindles travel up and down.

Ordinary mounting mode is applied here,

**US: UPRISE DS: DROP**

- \* Select US or DS according to the load and mounting positions.
- \* Anti-rotation measures must be taken because torque on screw will be caused when screw traveling up and down.

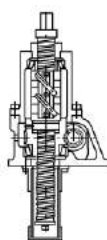

US

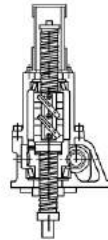

DS

**With Anti-rotation device.**

**UM: UPRISE DM: DROP**

- \* No rotation of screw, which only travel up and down.
- \* Select UM or DM according to the load and mounting positions.

**安装方位**

**Mounting position**

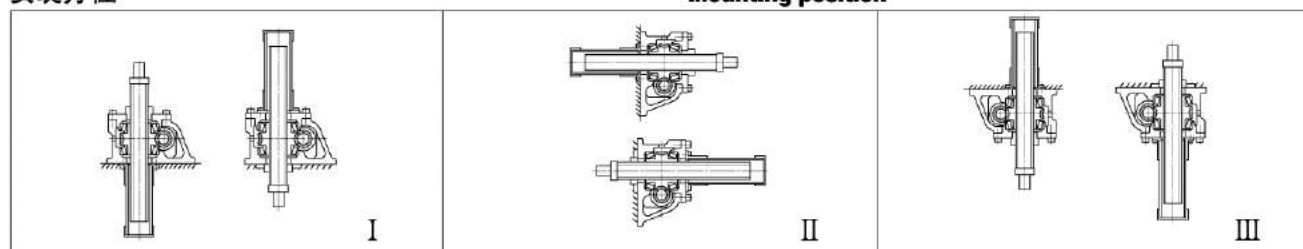

注: 采用III型安装方位时, 底脚安装螺栓的性能等级须为10.9级以上。

Note: Selecting mounting position III, the quality of bolt on housing feet reaches 10.9.



活动螺母构造升降机的型号表示方法:

Illustration of type with traveling nut



**活动螺母构造 (UR, DR)**

一般情况下, 升降机必须具有因丝杆轴的升降而产生的行程和丝杆罩所需的空间, 若想在有限的空间内增长行程时, 使用此活动螺母构造非常适应 (丝杆轴旋转, 活动螺母移动)。丝杆轴顶端为圆柱形, 所以在长行程时, 在轴端采用支撑方式, 可以得到很好的传动效果。

**JW with Traveling nut**

In general, Jack need enough space for screw's traveling journey and dust-hood. Using traveling nut can help jack realize longer traveling journey in limited space. The top end fittings are column, it can be a supporting point for a good transmission effect when a long traveling journey is selected.

UR: 押上 DR: 吊下

UR: uprise DR: drop

请根据载荷方向, 安装方向来选择合适的升降机 (押上或吊下)

Select UR or DR according to the load and mounting positions.

**活动螺母的安装方向 (P, R)**

选型和型号表示方法中, 还需注明螺母的放置方向 (如下图)

**Mounting direction of traveling nut (P, R)**

The mounting direction of traveling nut should be signed on drawing when selecting types.

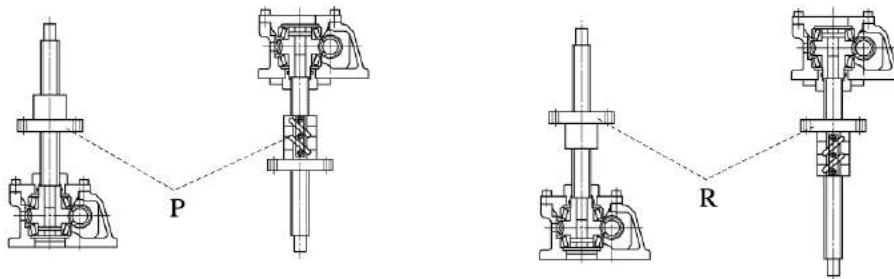

**安装方位 (I、II、III)**

**Mounting position of Jack (I, II, III)**

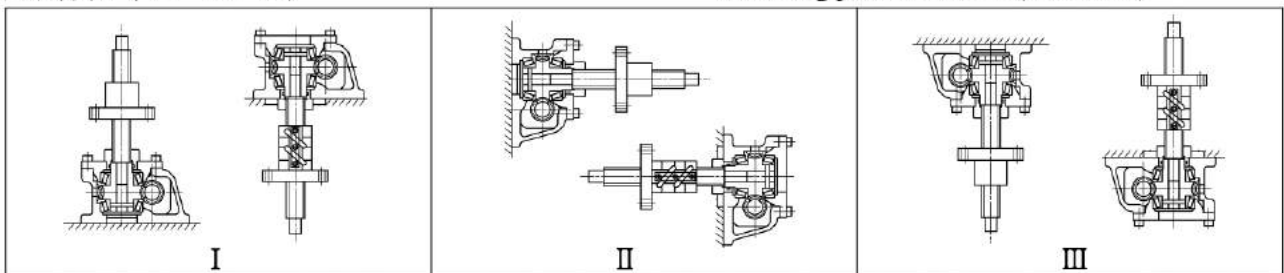

注: 采用III型安装方位时, 底脚安装螺栓的性能等级须为10.9级以上。

Note: Selecting mounting position III, the quality of bolt on housing feet reaches 10.9.

**注意事项：**

- 1) 选择升降机时不论静载、动载、冲击载荷均不得超过其允许承受的最大载荷，根据安全系数、使用行程、校对丝杆的稳定性选择具有充分容量的升降机；
- 2) 一定要注意丝杆轴转速与承受的载荷进行搭配，对于升降机的容许最大载荷、容许外加负载、容许丝杆轴的旋转速度等项目进行校验，如果超过产品的数据将会造成升降机设备整体的重大损伤；
- 3) 升降机在工作时其减速部表面温度应控制在-15℃~80℃的范围以内，确保活动螺母的表面温度也在上述范围以内；
- 4) 输入轴容许转速为1500r/min，输入轴不得超过此转速；
- 5) JWM和JWB都不可连续运转：  
单台升降机的负荷时间率(%ED)以30分为单位计算，JWM(梯形丝杆类型)的负荷时间内不得超过20%ED，JWB(普通滚珠丝杆)的负荷时间率不得超过30%ED，

负荷时间率%ED =

$$\frac{I \text{ 动作周期的工作时间}}{I \text{ 动作周期的工作时间} + I \text{ 动作周期的停歇时间}} \times 100\%$$

- 6) 对于在同一轴线上连接数台升降机时，请务必对输入轴强度进行校核，使每台升降机所承担的扭矩都应在其容许输入轴扭矩以内；
- 7) 驱动源的起动扭矩应确保在使用扭矩的200%以上；
- 8) 在零摄氏度以下工作时因受润滑油粘性变化的影响使得整机效率下降，所以必须选有充足的驱动源；
- 9) JWM型理论上具有自锁功能，但工作在振动冲击较大的场合时会导致自锁功能失灵，因此须外加一制动装置或选择带有制动的驱动源。  
JWB型升降机本身不具有自锁功能，为了防止由于轴向载荷和丝杆的自重而产生逆转，必须外加制动装置或选择带有制动的驱动源，请确保制动扭矩大于保持扭矩；

10) 升降机使用的环境如下

使用场所	Working Location	室内无雨水侵入的场所	Indoor location without rainwater
周围空气	Ambient Air	灰尘为一般工厂状态	Normal
环境温度	Ambient Temperature	-15℃~40℃	
相对湿度	Relative Humidity	85%以下	Less than 85%

- 11) 当升降机工作在多灰尘的场所中时请务必选择防尘罩伸缩套附件来保护丝杆，在室外使用时请务必考虑使用罩壳等装置，使机器不直接受到风吹雨打；
- 12) 在升降机工作时，不得进行人为的强行停机，否则将使升降机受到严重破损；
- 13) 在有负载的情况下，请不要将JWB型的输入轴驱动方式变为手动操作，负载有可能会造成输入轴旋转非常危险。

**Note:**

- 1) Select a Jack with sufficient capacity according to safety factor, service journey and stability. And stationary load, dynamic load and shock load must be lower than permissible maximum load.
- 2) Please note that rotation speed of screw must match load, permissible maximum load, permissible maximum outer load, and permissible rotation speed of screw must be verified. If these figures exceed that of products, jacks will be damaged greatly.
- 3) The surface temperature will be limited in -15° ~ 80° when jack working to ensure the temperature of traveling nuts in -15° ~ 80° .
- 4) Maximum input speed is 1500r/min.
- 5) JWM and JWB aren't suitable for continuous operation, Jack Duty(%ED) JWM duty(%ED) cannot exceed 20%ED, JWB duty(%ED) cannot exceed 30%ED,

Duty %ED =

$$\frac{\text{jack operating time(lift \& lower cycle)}}{\text{Elapsed cycle time}} \times 100\%$$

- 6) When several Jacks are connected on the same axial line, the loaded torque with each Jack must be verified and limited within permissible input torque.
- 7) Starting torque must be 200% of service torque.
- 8) At below 0° ambient temperature, changed adhesion of lubrication will lower Jack's efficiency so that sufficient drive is necessary.
- 9) JWM has self-lock function, but an Extra braking device or drive source with braking device is necessary to be equipped because self-lock will be of mal-function when Jack is loaded a heavy shock.  
JWB has no self-lock function, to avoid backspin of screw under axial load and its weight, a braking device or drive source with braking device is necessary to be equipped and braking torque must be larger than operating torque of Jack.

10) Jack's operating conditions

- 11) When working in dusty space, Jack must be equipped with elastic dust-hood on screw; in open air, shield must be equipped to prevent exposure to wind and rain.
- 12) When working, Jack cannot be forced to stop, or it will be damaged seriously.
- 13) Under load, don't change motor drive mode into manual drive, or which will cause backspin of screw and cause great danger.



选型方法:

How to select type:

升降机型号的确定:

Determine Jack's type:

计算总机的当量载荷Ws (N)

Calculate total equivalent load Ws (N):

$$W_s = \text{最大载荷 } W_{\max} \times \text{使用系数 } f_1(N)$$

$$W_s = W_{\max} \times f_1$$

被驱动设备系数 (f1) 表:

Service factor for driven machine (f1):

载荷性质 Load character	使用举例 Example	被驱动设备系数 Factor for driven machine (f1)
无冲击载荷, 负荷惯性小 shockless load & small inertia load	开关、阀门传送带切换装置 Switch, valve transmission belt swithing device	1.0 ~ 1.3
轻微冲击载荷, 负荷惯性中等 moderate shock & moderate inertia	各种移动装置, 升降用各种升降机 All kinds of moving devices, all kinds of elevators	1.3 ~ 1.5
大冲击振动载荷, 负荷惯性大 heavy shock & large inertia	用台车搬运东西; 保持压延滚轮的位置 Carrying something by trolley; to keep the position of idling gear	1.5 ~ 3.0

计算单台升降机的当量载荷W,

Calculate equivalent load of single Jack,

$$W = \frac{W_s}{\text{连动台数} \times \text{连动系数 } f_d}$$

$$W = \frac{W_s}{\text{Number} \times \text{Linkage factor } (f_d)}$$

连动系数 Linkage factor(f<sub>d</sub>):

连动台数 Number of linkage jack	1	2	3	4	5~8
连动系数 Linkage factor	1	0.95	0.9	0.85	0.8

确定升降机型号:

Temporarily determine Jack type:

充分考虑载重, 速度, 行程, 效率, 驱动源后暂时选定型号

Temporarily determine Jack type after taking full consideration of load, speed, journey, efficiency and drive source.

根据使用行程、环境条件、输出顶端的联接方式, 确定升降机的整体型号。

Determine JW type according to service journey, ambient conditions, connection mode of end-fittings.

输入功率校核:

Verify input power

负载所需输入功率与许容最大输入功率相比较  
如果超过请提高型号或降低丝杆轴转速再计算。

If required input power under load exceeds permissible maximum input power, please select larger type or lower the speed of screw rotation.

负载所需输入功率计算 Calculation of required input power under load :

所需输入轴转速 Required rotation speed of input shaft	n <sub>1</sub> (r/min)	$n_1 = \frac{V}{L_i} \times i$
所需输入轴扭矩 Required torque of input shaft	T <sub>1</sub> (N · m)	$T_1 = \frac{W \times L_i}{2\pi \times i \times \eta} + T_0$
所需输入功率 Required input power	P <sub>1</sub> (kW)	$P_1 = \frac{T_1 \times n_1}{9550}$

V:升降机丝杆轴(活动螺母)升降速度 mm/min L<sub>i</sub>:丝杆螺距 (mm)  
i:减速比 W:单台升降机当量载荷 (N) π:圆周率  
η:升降机的综合效率 T<sub>0</sub>:空载扭矩 (N·m)  
(L<sub>i</sub>、i、η、T<sub>0</sub>参照基本参数表)

V: linear speed of screw mm/min L:Pitch of screw (m)  
i:ratio W:equivalent load of single jack π:pi  
η:Integrated efficiency T<sub>0</sub>:No-load torque (Nm)  
(L<sub>i</sub>、i、η、T<sub>0</sub> refer to basic parameter table)

丝杆稳定性校核

Verify the stability of screw:

当丝杆承受轴向压缩载荷时, 请对其进行稳定性校核, 如超过其临界载荷值请提高型号后再计算。

Please verify the stability of screw under axial load, larger type should be used when load exceed the critical load.

升降机丝杆临界稳定载荷通过以下公式计算:

The formula to calculate the critical load as follows,

$P_{CR} = f_m \times \left(\frac{d^2}{L_a}\right)^2$	确保 ensure	$P_{CR} > W \times SF \quad (SF = 4)$
--	--------------	---------------------------------------

P<sub>CR</sub>: 临界载荷 (N)  
d: 丝杆底径mm(参照基本参数表)  
f<sub>m</sub>: 支撑系数  
L<sub>a</sub>: 作用点间距离mm  
W: 单台升降机当量载荷 (N)  
SF: 安全系数 (一般SF=4)

P<sub>CR</sub>:Critical load (N)  
d : small diameter of screw end (mm) (refer to basic parameter table)  
f<sub>m</sub> : support factor  
L<sub>a</sub> : distance between load-supporting point and mounting point as drawing.  
W : equivalent load of single Jack (N)  
SF : safety factor (SF=4 as usual)

丝杆轴稳定性校验时,  $L_a$  ( $L_a$ 值计算根据各型号尺寸) 与  $f_m$  (支撑系数) 选取如下:

Verifying the stability of screw, the values of  $L_a$  and  $f_m$  as follows,

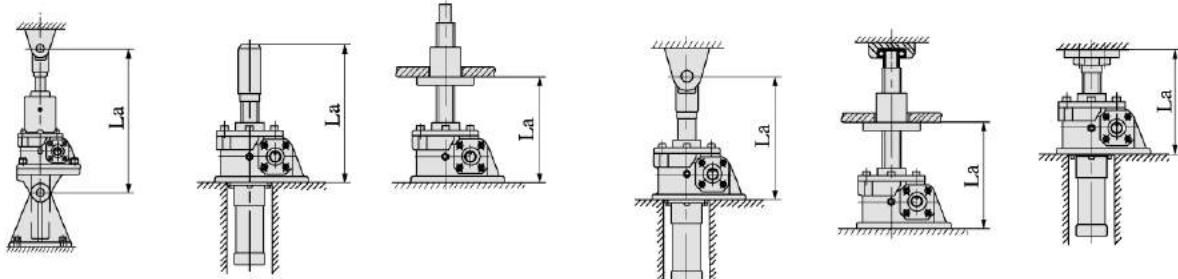

两端支撑  $f_m=10 \times 10^4$   
support at both ends  $f_m=10 \times 10^4$

底座固定轴端自由  $f_m=2.5 \times 10^4$   
Foot-mounted & movable shaft end  $f_m=2.5 \times 10^4$

底座固定轴端支撑或固定  $f_m=20 \times 10^4$   
Foot-mounted & shaft end supporting or fixed  $f_m=20 \times 10^4$

**临界转速校核**

如为活动螺母选型时, 请务必将丝杆轴转速控制在临界转速以下, 若超出临界转速, 请提高型号再计算。

Verifying critical rotation speed:

Using traveling nut, the rotation speed of screw must be lower than critical speed, if no, please select larger type and calculate again.

$$n_c = \frac{96 \times f_n \times d \times 10^6}{L_b^2}$$

$$n_s = \frac{n_1}{i}$$

$n_c$ : 临界转速 r/min

$n_s$ : 丝杆转速 r/min

$d$ : 丝杆底径 mm(参照基本参数表)

$n_1$ : 输入速度 r/min

$f_n$ : 长度系数

$i$ : 减速比

$L_b$ : 支撑间距离 mm

$n_c$ : Permissible rotation speed of screw

$n_s$ : Rotational speed of screw

$d$ : Small diameter of screw (refer to basic parameter table)

$n_1$ : Rotational speed of input shaft

$f_n$ : Length factor

$i$ : ratio

$L_b$ : Distance between both supporting face

丝杆轴转速校验时,  $L_b$  ( $L_b$ 值计算根据各型号尺寸) 与  $f_n$  (长度系数) 选取如下:

Verifying the rotation speed of screw, the values of  $L_b$  and  $f_n$  as follows,

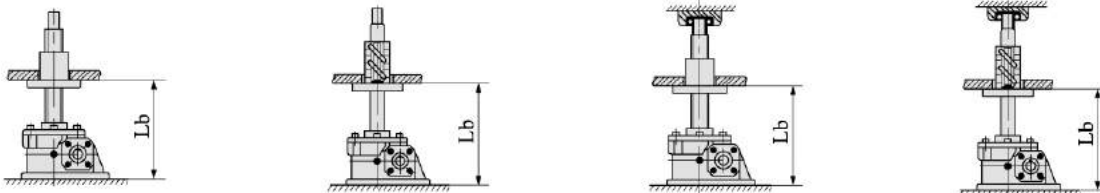

轴端自由  $f_n=0.36$   
Movable shaft end  $f_n=0.36$

轴端支撑  $f_n=1.56$   
Shaft end supporting  $f_n=1.56$

请确保:  $n_c > n_s$

Ensure:  $n_c > n_s$

计算举例: JW200UR-H1200PI在输入转速为1200r/min, 轴端支撑下运转, 根据外形尺寸与传动能力表查得:

Example for calculation:

Take JW200UR-H1200PI as example,  $n_1=1200$ r/min, connecting mode of top-end : I, we can know  $d=49.3$ ,  $L_b=1437$  referring to dimension and transmission capacity table.

$d=49.3$   $L_b=1437$

$$n_s = \frac{n_1}{i} = \frac{1200}{8} = 150 \text{r/min}$$

$$n_c = \frac{96 \times f_n \times d \times 10^6}{L_b^2} = \frac{96 \times 1.56 \times 49.3 \times 10^6}{(1437)^2} = 3575 \text{r/min}$$

$$n_c = 3575 \text{r/min} > n_s = 150 \text{r/min} \dots \dots \text{ok.}$$



当有横向载荷时，请外加导向器。

When there is radial load, please add guiding device.

JWM 许用横向载荷 Permitted radial load  $F_r(N)$ :

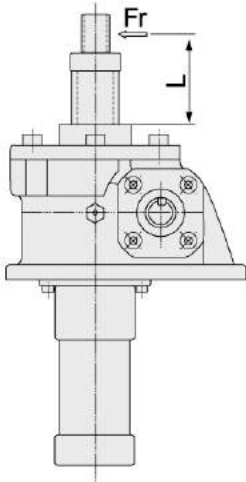

$F_r(N)$ / Type / L (mm)	010	025	050	100	150	200	300	500	750	1000
100	318	570	2500	4010	4610	8210	38200	85300	73500	186200
200	159	290	1250	2010	2300	4110	23000	50400	56800	145000
300	106	190	830	1340	1540	2740	15300	33600	46100	104700
400	79	140	620	1000	1150	2050	11400	25200	39300	78500
500	64	110	500	800	920	1640	9100	20200	33900	62800
600	53	100	420	670	770	1370	7600	16800	29900	52300
700	51	90	360	570	660	1170	6500	14400	26700	44800
800	48	90	310	500	580	1030	5700	12600	24100	39200
900	45	90	280	450	510	910	5000	11200	22000	34800
1000	42	90	250	400	460	820	4500	10100	20200	31300

JWB或JWM超过许用横向载荷时，请外加导向装置，举例如下：

When operating radial load exceeds critical radial load, please add guiding device, for example,

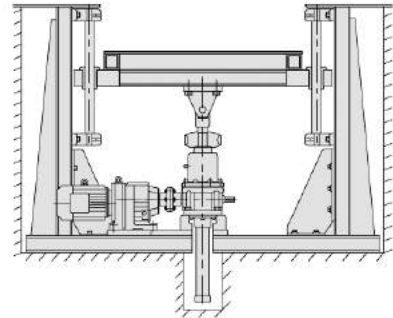
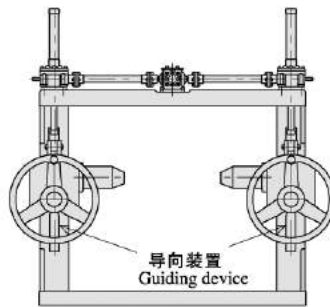
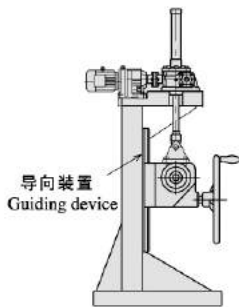

当升降机传动配置为串联时(即同一轴线配置了两个或以上数量的升降机)如图须对各升降机输入轴端进行强度校核：

Please verify input torque of each Jack when several Jack are connected on the same input axial line as the following,

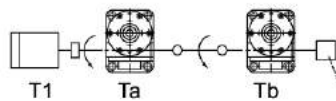

Ta: 为升降机a的所需输入扭矩

Ta: Required torque of input shaft of jack a.

Tb: 为升降机b的所需输入扭矩

Tb: Required torque of input shaft of jack b.

电机必需的扭矩  $T_1 = T_a + T_b <$  升降机a的容许输入轴扭矩

Required torque of motor  $T_1 = T_a + T_b <$

Promitted input torque of jack a.

### 升降机选择举例：

### Jack selection example:

例题：4台连动押上用，结构如下图所示的4台连动模式，工厂内保持常温，有少许灰尘，有横向负荷在升降机侧面设置了导向器，安装状态采用底座固定，轴端采用一固定一支撑，电源为三相380V/50Hz，使用频率为2次/小时×8小时

Example: Four Jacks, linked as the following drawing, normal temperature, thin dust, radial load, with guiding devices on one side, foot-mounted, fixed the screw top-end, 380v/50Hz, service frequency: 2 times/hour, service time : 8 hours.

- 1.最大轴向载荷:88.2 KN/4台
- 2.升降速度:10mm/s (600mm/min)
- 3.使用行程:260mm

1. Maximum axial load ; 88.2KN/4 Jacks
2. Linear speed : 10mm/s (600mm/min)
3. Service journey : 260mm

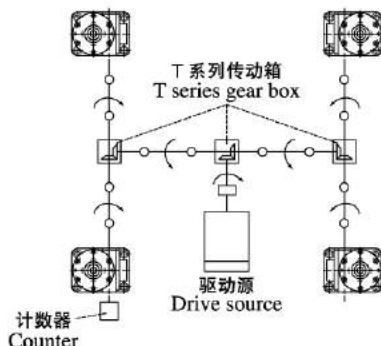

#### 升降机型号确定

#### Determine Jack type,

- 1). 计算总机当量载荷 $W_s$  (取被驱动设备系数为1.3)  
 $W_s = W_{max} \cdot f_1 = 88200 \times 1.3 = 114660N$
- 2). 计算单台当量载荷 $W$

- 1) Calculate total equivalent load  $W_s$   
(Factor for driven machine is 1.3)  
 $W_s = W_{max} \cdot f_1 = 88200 \times 1.3 = 114660N$
- 2) Calculate equivalent load of single jack:

$$W = \frac{114660}{4 \times 0.85} = 33724N$$

- 3). 暂定型号：  
考虑速度、效率、驱动源、载重后暂定选择 JWB050USH (参照基本参数表)
- 4). 行程校核：  
使用行程为260mm，充分考虑余量后选定行程为300mm (参照JWB050US尺寸表)
- 5). 输入功率校核：  
(1)所需输入功率计算：

- 3) Temporarily determine type,  
Temporarily determine JWB050USH according to speed, efficiency, drive and Load (refer to basic parameter table)
- 4) Verify journey:  
Service journey is 260mm, determine journey should be 300 after considering surplus.  
(Please refer to dimension sheet of JWB050US ).
- 5) Check input power:  
(1) Calculate required input power:

$$\textcircled{1} n_1 = \frac{V}{L_1} \times i = \frac{0.60}{0.010} \times 6 = 360r/min$$

$$\textcircled{2} T_1 = \frac{W \times L_1}{2\pi \times i \times \eta} + T_0$$

$$\textcircled{3} P_1 = \frac{T_1 \times n_1}{9550}$$

$$= \frac{33724 \times 0.010}{2 \times 3.14 \times 6 \times 0.64} + 1.37 = 15.4Nm$$

$$= \frac{15.4 \times 360}{9550} = 0.58kW$$

(2)参照基本参数表,  $P_{max} = 2.2kW > P_1 \dots \dots OK$

(2) Refer to basic parameter table,  $P_{max} = 2.2kW > P_1 \dots \dots OK$

6). 丝杆稳定性校核：  
因为施加压缩载荷，根据传动能力表及外形尺寸图得出：

6) Verify the stability of screw  
For under axial load, refer to transmission table and dimension for the following figures,

$$d=31.3 \quad L_a=604+33=637 \quad f_m=20 \times 10^4 \quad SF=4$$

$$P_{CR} = f_m \times \left( \frac{d^2}{L_a} \right)^2 = 20 \times 10^4 \times \left( \frac{31.3^2}{637} \right)^2 = 473073N$$

$$P_F = \frac{P_{CR}}{SF} = \frac{473073}{4} = 118268 > W = 33724$$

... ..OK



附件的确认:

Accessory confirmation:

C型安装:

Support (Mode C mounting):

支座安装广泛应用于开关装置、倾斜装置。如图:

Support-mounted mode widely apply to tilting equipment.

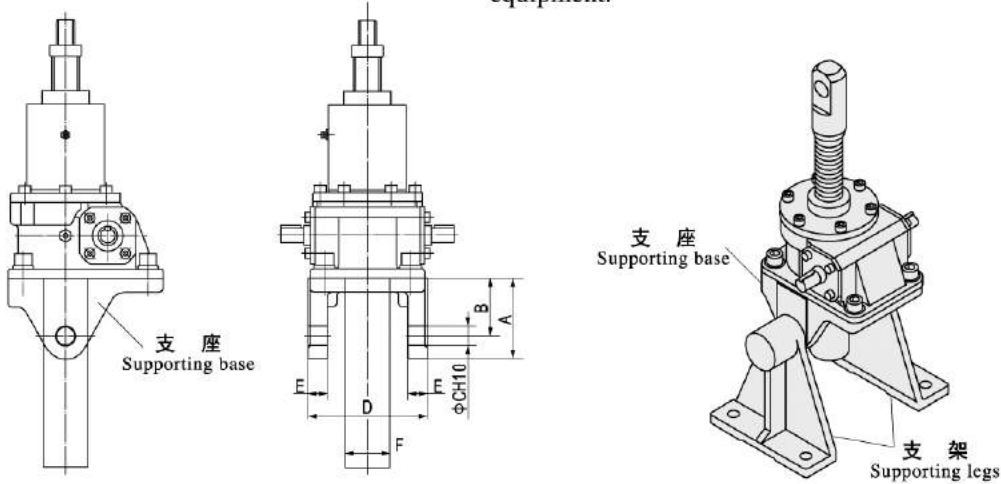

型号	A	B	C	D	E	F
010	75	60	15	86	15	35
025	100	75	20	115	20	45
050	105	75	25	158	25	58
100	145	100	40	201	30	76.3
150	155	105	50	224	44	76.3
200	173	110	63	244	50	89.1



支架

Supporting legs:

支座与支架配合, 实现多方位升降。

Matching supporting base and legs realizes multi-angles lifting and lowering.

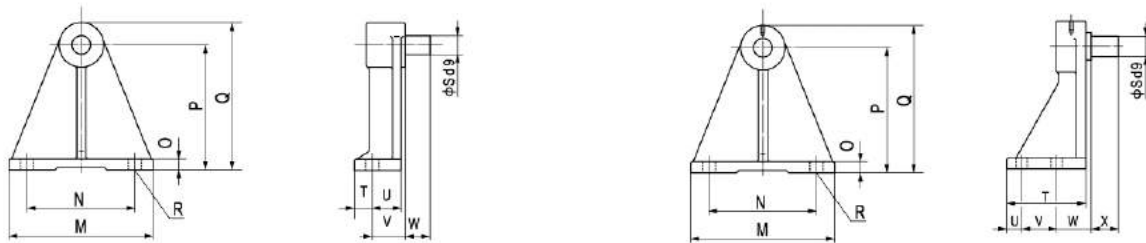

JW010-JW050

JW100-JW200

型号	M	N	O	P	Q	R	S	T	U	V	W	X
010	180	130	15	150	178	2-φ18	15	25	40	45	17	-
025	180	130	15	150	178	2-φ18	20	25	40	45	30	-
050	200	150	15	170	200	2-φ18	25	25	40	45	35	-
100	280	220	22	240	290	4-φ22	40	159	30	70	70	55
150	360	280	27	300	360	4-φ33	50	195	40	85	85	70
200	400	320	30	380	450	4-φ33	63	210	40	90	90	75

**手轮盘:**

此件只适应于JWM型工作在冲击、振动不大的场合，请不要应用在JWB结构中。  
手动操作扭矩=所需输入扭矩/手轮操作盘半径

**Hand wheel:**

Hand wheel only apply to JWM under light shock or vibration condition but not for JWB.

$$M_{\text{handwheel}} = M_{\text{required}} / T_{\text{handwheel}}$$

**型号表示:**

JWM025US - H200MI

- NV100

升降机型号 (见180页)  
Refer to 180页

手轮盘型号  
Hand wheel mode

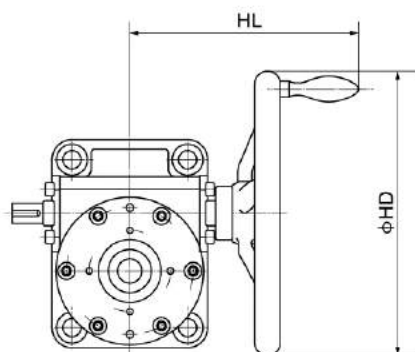

**尺寸表:**

**Dimension sheet:**

(mm)

型号 Type	NV80		NV100		NV200		NV250		NV450	
	HD	HL	HD	HL	HD	HL	HD	HL	HD	HL
JWM010	80	122	100	125	—	—	—	—	—	—
JWM025	—	—	100	140	200	198	—	—	—	—
JWM050	—	—	—	—	200	221	250	229	—	—
JWM100	—	—	—	—	—	—	250	242	450	295
JWM150	—	—	—	—	—	—	250	247	450	300
JWM200	—	—	—	—	—	—	—	—	450	304

注：手轮为外购件，以定货时实物尺寸为准。

Note: The dimension of hand wheel is subject to product purchased from other factories.

**双头输出:**

适用于开闭装置、反转装置。

**Double end output:**

Apply to open and close devices, reversing devices.

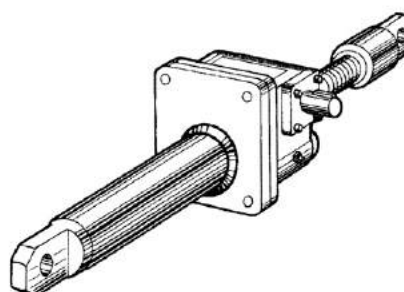
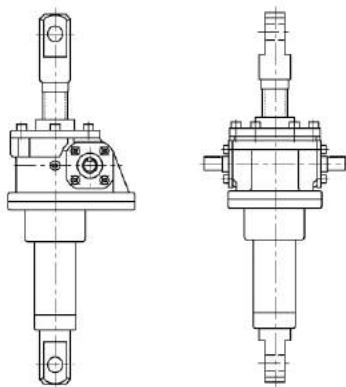



组合型式:

Combination of JW series:

电机直联:

Direct-connected-motor:

型号表示 Illustration of types:

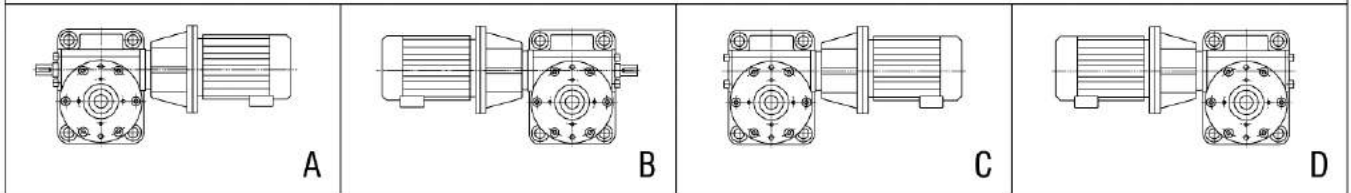
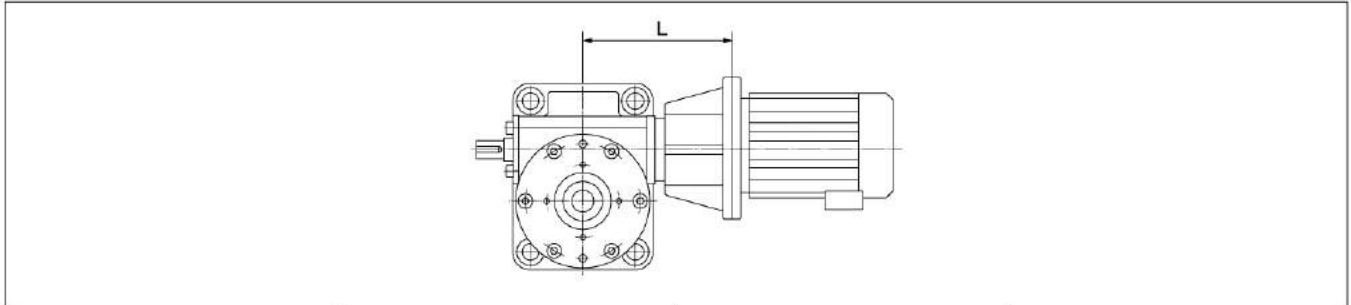
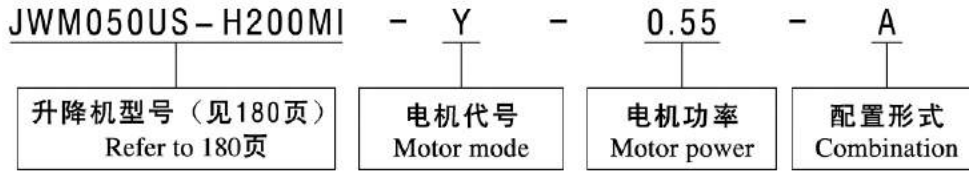

型号	JWM010				JWM025						JWM050					
电机功率 (kW) Motor Power	0.12	0.18	0.25*	0.37*	0.12	0.18	0.25	0.37	0.55*	0.75*	0.25	0.37	0.55	0.75	1.1*	1.5*
L (mm)	136				142						170					

型号	JWM100						JWM150						JWM200					
电机功率 (kW) Motor Power	0.37	0.55	0.75	1.1	1.5	2.2*	0.55	0.75	1.1	1.5	2.2*	3*	0.75	1.1	1.15	2.2	3	4*
L (mm)	225						232						260					

注: 1. 电机功率的选择应符合传动能力表;  
2. 表中所列功率为4极电机功率;  
3. 当与所联电机为6极或标有“\*”的电机为变频、制动时, 因电机过重, 应选择带有底脚安装的电机。

Note: 1. Motor power must accord with JM basic parameter table.  
2. 4-pole motor power are available in the table.  
3. 6-pole motors or “\*” frequency conversion and braking motors should be foot-mounted for their heavy weight.

与减速电机组合式 Combination with gear motor:

型号表示 Illustration of types:

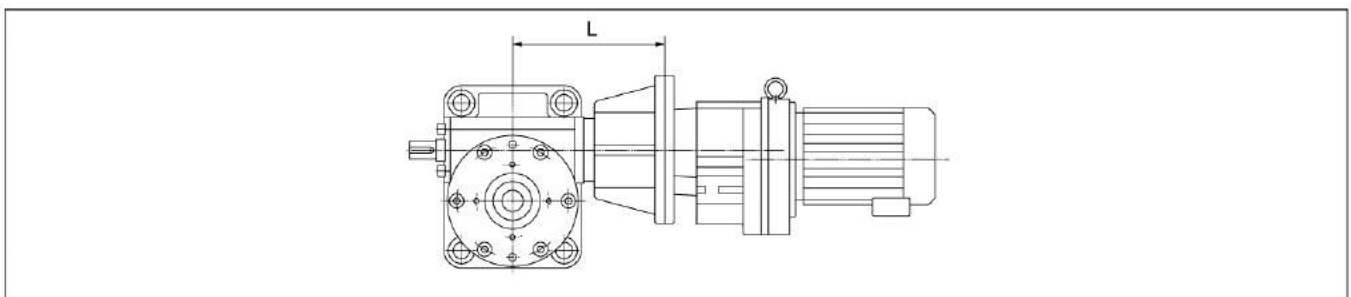

注: 当直联的减速电机重量过重时, 请咨询我司。

Note: If gear motor is over weight, consult us please.

应用举例

Application example:

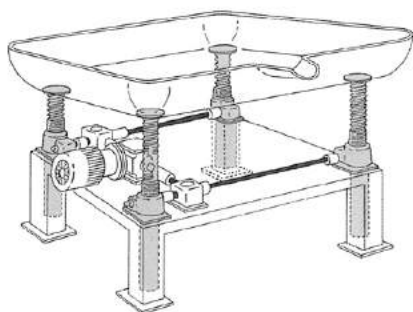

平台升降  
Ascending and descending of flat slab

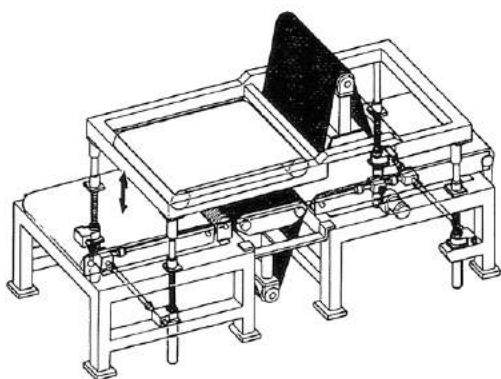
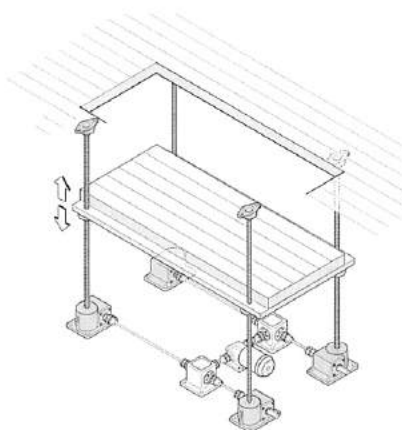

调整表面加工机的工作高度  
Adjust operation height of surface machining tool

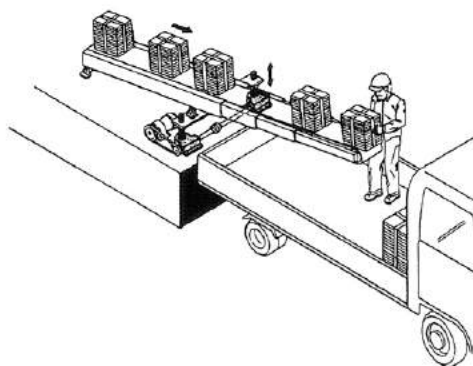

调整滑动传送带的倾斜程度  
Adjust inclination pitch of conveyer apron

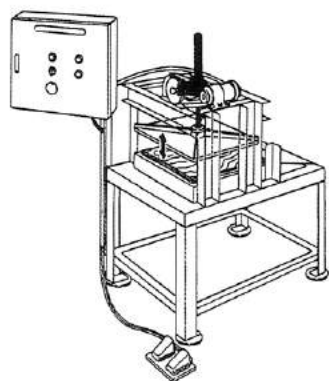

更改校正器的作业高度  
Operation height of straightening machine

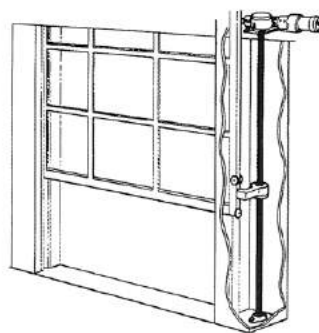

大型窗户（门）自动开关  
Automatic switch on large windows (doors)

JW



JWM010

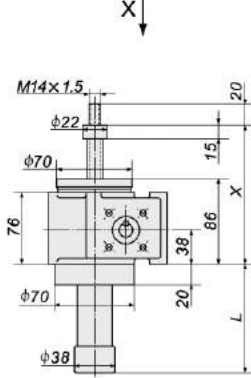
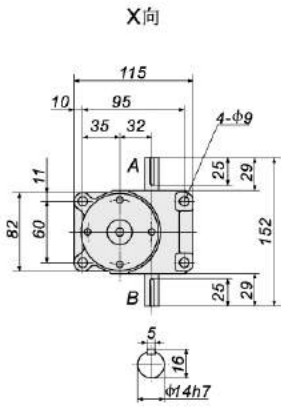

JWM010US

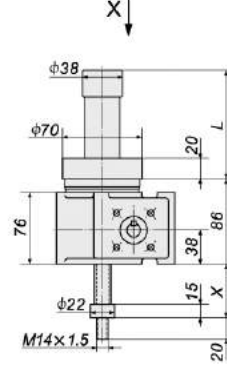

JWM010DS

行程 (mm) Journey	U S					
	X		X <sup>(1)</sup>		L	m (kg)
	MIN	MAX	MIN	MAX		
100	101	201	161	261	194	5.5
200	101	301	161	361	294	5.7
300	101	401	201	501	434	6.1
400	101	501	201	601	534	6.3
500	101	601	236	736	669	6.6
600	101	701	236	836	769	6.9
800	101	901	271	1071	1004	7.5

行程 (mm) Journey	D S					
	X		X <sup>(1)</sup>		L	m (kg)
	MIN	MAX	MIN	MAX		
100	25	125	75	175	194	5.5
200	25	225	75	275	294	5.7
300	25	325	115	415	434	6.1
400	25	425	115	515	534	6.3
500	25	525	150	650	669	6.6
600	25	625	150	750	769	6.9
800	25	825	185	985	1004	7.5

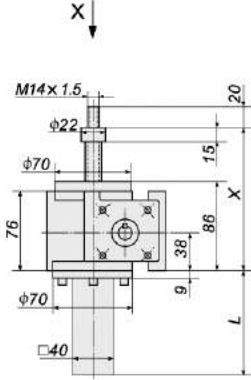
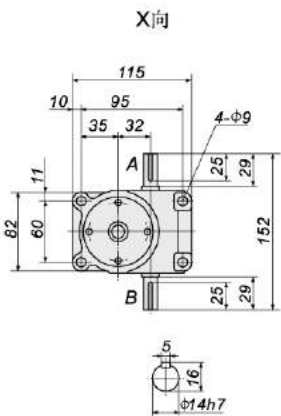

JWM010UM

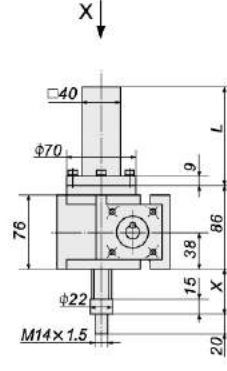

JWM010DM

行程 (mm) Journey	U M					
	X		X <sup>(1)</sup>		L	m (kg)
	MIN	MAX	MIN	MAX		
100	101	201	161	261	194	6.6
200	101	301	161	361	294	7.2
300	101	401	201	501	434	8.1
400	101	501	201	601	534	8.8
500	101	601	236	736	669	9.6
600	101	701	236	836	769	11
800	101	901	271	1071	1004	12

行程 (mm) Journey	D M					
	X		X <sup>(1)</sup>		L	m (kg)
	MIN	MAX	MIN	MAX		
100	25	125	75	175	194	6.6
200	25	225	75	275	294	7.2
300	25	325	115	415	434	8.1
400	25	425	115	515	534	8.8
500	25	525	150	650	669	9.6
600	25	625	150	750	769	11
800	25	825	185	985	1004	12

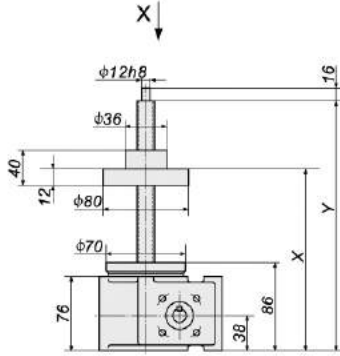
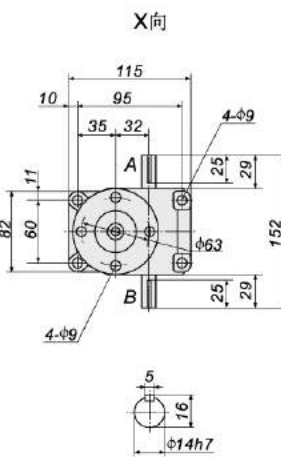
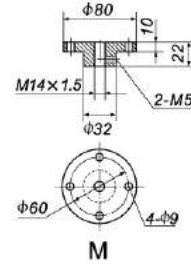
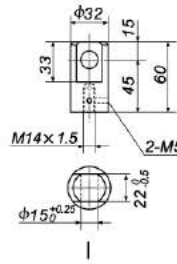
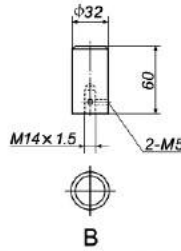
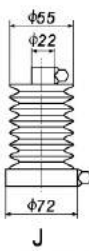

JWM010UR

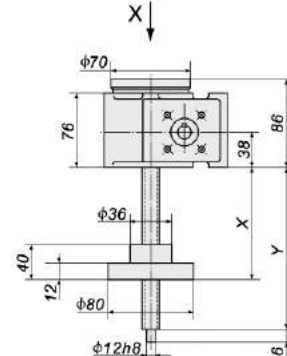

JWM010DR

行程 (mm) Journey	U R			
	X		Y	m (kg)
	MIN	MAX		
100	108	208	246	5.9
200	108	308	346	6.1
300	108	408	446	6.2
400	108	508	546	6.4
500	108	608	646	6.6
600	108	708	746	6.8
800	108	908	946	7.2

行程 (mm) Journey	D R			
	X		Y	m (kg)
	MIN	MAX		
100	50	150	160	5.9
200	50	250	260	6.1
300	50	350	360	6.2
400	50	450	460	6.4
500	50	550	560	6.6
600	50	650	660	6.8
800	50	850	860	7.2

注: X<sup>(1)</sup> 为加防尘罩时尺寸。

Note: "X<sup>(1)</sup>" is the dimension of jack with dust hood.



JWM025

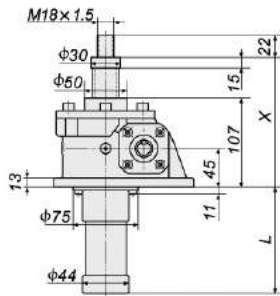
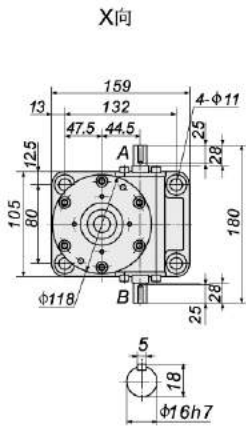

JWM025US

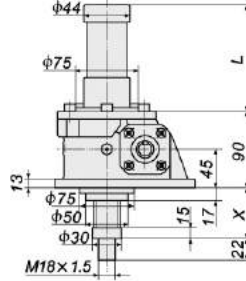

JWM025DS

行程 (mm) Journey	U S					
	X		X <sup>(1)</sup>		L	m (kg)
	MIN	MAX	MIN	MAX		
100	132	232	147	247	149	7.7
200	132	332	147	347	249	8.1
300	132	432	167	467	369	8.5
400	132	532	167	567	469	8.9
500	132	632	187	687	589	9.4
600	132	732	187	787	689	9.8
800	132	932	207	1007	909	11
1000	132	1132	227	1227	1129	12

行程 (mm) Journey	D S					
	X		X <sup>(1)</sup>		L	m (kg)
	MIN	MAX	MIN	MAX		
100	42	142	57	157	149	7.7
200	42	242	57	257	249	8.1
300	42	342	77	377	369	8.5
400	42	442	77	477	469	8.9
500	42	542	97	597	589	9.4
600	42	642	97	697	689	9.8
800	42	842	117	917	909	11
1000	42	1042	137	1137	1129	12

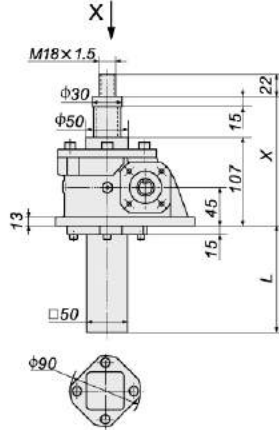
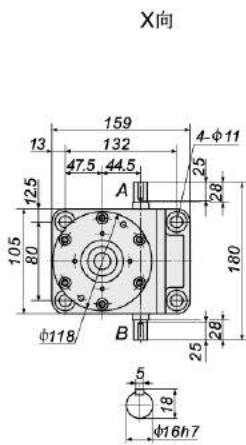

JWM025UM

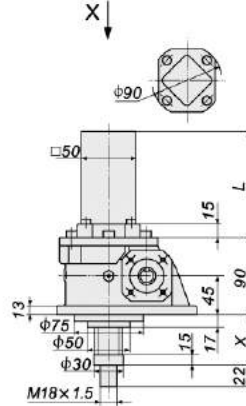

JWM025DM

行程 (mm) Journey	U M					
	X		X <sup>(1)</sup>		L	m (kg)
	MIN	MAX	MIN	MAX		
100	42	142	57	157	175	10
200	42	242	57	257	275	12
300	42	342	77	377	395	13
400	42	442	77	477	495	14
500	42	542	97	597	615	15
600	42	642	97	697	715	17
800	42	842	117	917	935	19
1000	42	1042	137	1137	1155	21

行程 (mm) Journey	D M					
	X		X <sup>(1)</sup>		L	m (kg)
	MIN	MAX	MIN	MAX		
100	42	142	57	157	175	10
200	42	242	57	257	275	12
300	42	342	77	377	395	13
400	42	442	77	477	495	14
500	42	542	97	597	615	15
600	42	642	97	697	715	17
800	42	842	117	917	935	19
1000	42	1042	137	1137	1155	21



J

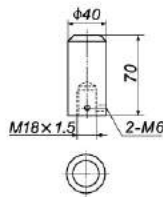

B

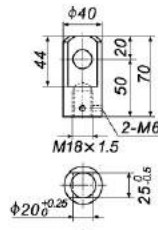

I

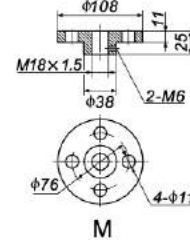

M

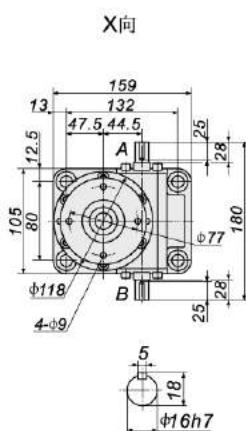

JWM025UR

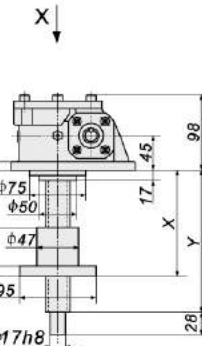
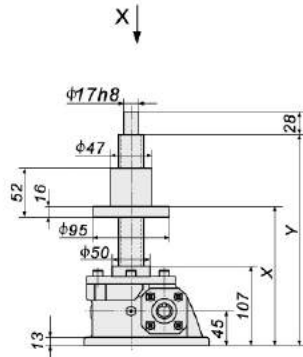

JWM025DR

行程 (mm) Journey	U R				
	X		Y		m (kg)
	MIN	MAX	MIN	MAX	
100	133	233	279	379	9.2
200	133	333	279	479	9.5
300	133	433	279	579	9.9
400	133	533	279	679	11
500	133	633	279	779	11
600	133	733	279	879	12
800	133	933	279	1079	12
1000	133	1133	279	1279	13

行程 (mm) Journey	D R				
	X		Y		m (kg)
	MIN	MAX	MIN	MAX	
100	79	179	189	289	9.2
200	79	279	189	389	9.5
300	79	379	189	489	9.9
400	79	479	189	589	11
500	79	579	189	689	11
600	79	679	189	789	12
800	79	779	189	889	12
1000	79	879	189	989	13

注: X<sup>(1)</sup>为加防尘罩时尺寸。

Note: "X<sup>(1)</sup>" is the dimension of jack with dust hood.





JWM050

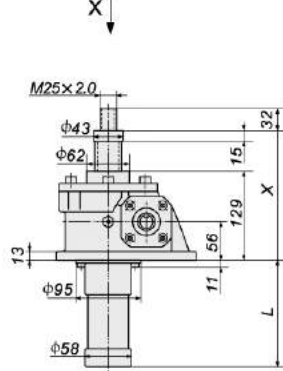
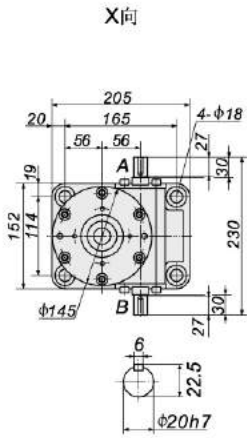

JWM050US

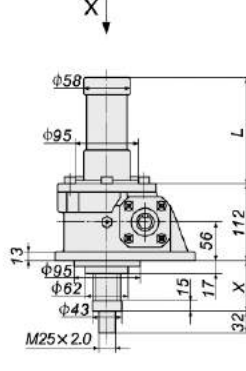

JWM050DS

行程 (mm) Journey	U S					
	X		X <sup>(1)</sup>		L	m (kg)
	MIN	MAX	MIN	MAX		
100	154	254	169	269	147	18
200	154	354	169	369	247	19
300	154	454	189	489	367	20
400	154	554	189	589	467	21
500	154	654	209	709	587	22
600	154	754	209	809	687	23
800	154	954	229	1029	907	25
1000	154	1154	249	1249	1127	27

行程 (mm) Journey	D S					
	X		X <sup>(1)</sup>		L	m (kg)
	MIN	MAX	MIN	MAX		
100	42	142	57	157	147	18
200	42	242	57	257	247	19
300	42	342	77	377	367	20
400	42	442	77	477	467	21
500	42	542	97	597	587	22
600	42	642	97	697	687	23
800	42	842	117	917	907	25
1000	42	1042	137	1137	1127	27

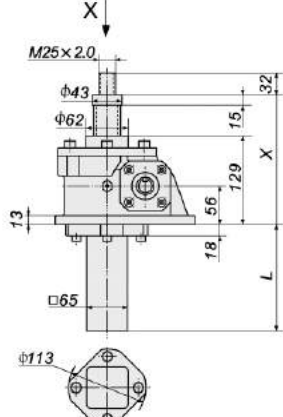
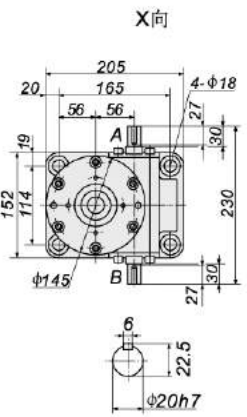

JWM050UM

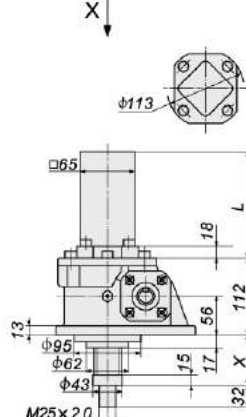

JWM050DM

行程 (mm) Journey	U M					
	X		X <sup>(1)</sup>		L	m (kg)
	MIN	MAX	MIN	MAX		
100	154	254	169	269	175	22
200	154	354	169	369	275	24
300	154	454	189	489	395	26
400	154	554	189	589	495	28
500	154	654	209	709	615	30
600	154	754	209	809	715	32
800	154	954	229	1029	935	36
1000	154	1154	249	1249	1155	40

行程 (mm) Journey	D M					
	X		X <sup>(1)</sup>		L	m (kg)
	MIN	MAX	MIN	MAX		
100	42	142	57	157	175	22
200	42	242	57	257	275	24
300	42	342	77	377	395	26
400	42	442	77	477	495	28
500	42	542	97	597	615	30
600	42	642	97	697	715	32
800	42	842	117	917	935	36
1000	42	1042	137	1137	1155	40



J

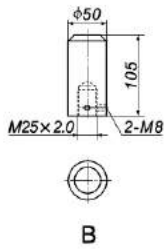

B

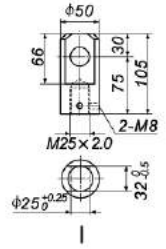

I

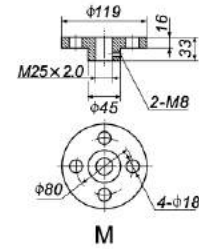

M

JW

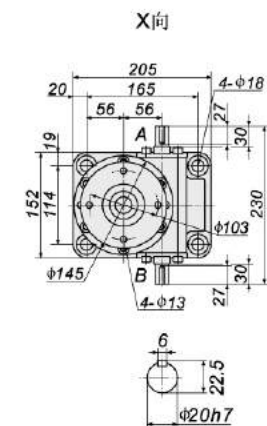

JWM050UR

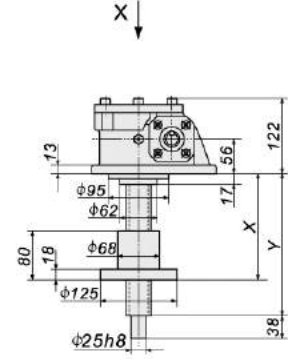
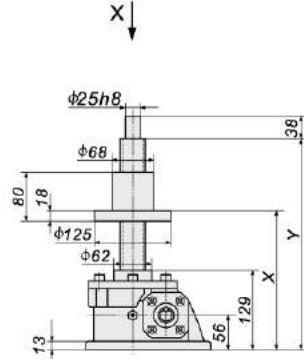

JWM050DR

行程 (mm) Journey	U R			
	X		Y	m (kg)
	MIN	MAX		
100	157	257	330	22
200	157	357	430	22
300	157	457	530	23
400	157	557	630	24
500	157	657	730	25
600	157	757	830	26
800	157	957	1030	27
1000	157	1157	1230	29

行程 (mm) Journey	D R			
	X		Y	m (kg)
	MIN	MAX		
100	107	207	218	22
200	107	307	318	22
300	107	407	418	23
400	107	507	518	24
500	107	607	618	25
600	107	707	718	26
800	107	907	918	27
1000	107	1107	1118	29

注: X<sup>(1)</sup>为加防尘罩时尺寸。

Note: "X<sup>(1)</sup>" is the dimension of jack with dust hood.



JWM100

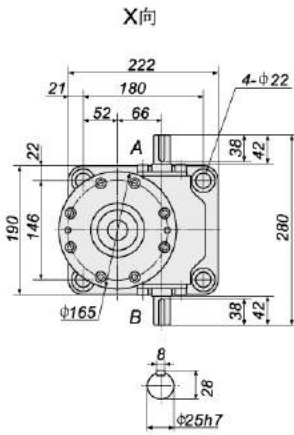

JWM100US

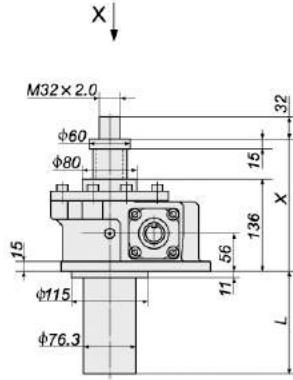

JWM100DS

行程 (mm) Journey	U S					
	X		X <sup>(1)</sup>		L	m (kg)
	MIN	MAX	MIN	MAX		
100	161	261	171	271	151	27
200	161	361	171	371	252	29
300	161	461	186	486	366	32
400	161	561	186	586	466	34
500	161	661	211	711	591	37
600	161	761	211	811	691	40
800	161	961	226	1026	906	45
1000	161	1161	236	1236	1116	50
1200	161	1361	261	1461	1341	56

行程 (mm) Journey	D S					
	X		X <sup>(1)</sup>		L	m (kg)
	MIN	MAX	MIN	MAX		
100	42	142	52	152	151	27
200	42	242	52	252	252	29
300	42	342	67	367	366	32
400	42	442	67	467	466	34
500	42	542	92	592	591	37
600	42	642	92	692	691	40
800	42	842	107	907	906	45
1000	42	1042	117	1117	1116	50
1200	42	1242	142	1342	1341	56

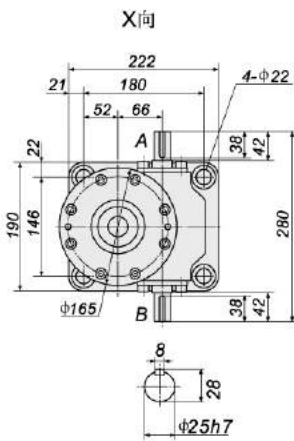

JWM100UM

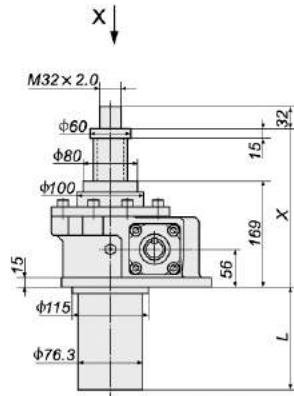

JWM100DM

行程 (mm) Journey	U M					
	X		X <sup>(1)</sup>		L	m (kg)
	MIN	MAX	MIN	MAX		
100	194	294	204	304	151	30
200	194	394	204	404	252	32
300	194	494	219	519	366	35
400	194	594	219	619	466	37
500	194	694	244	744	591	40
600	194	794	244	844	691	43
800	194	994	259	1059	906	48
1000	194	1194	269	1269	1116	53
1200	194	1394	294	1494	1341	58

行程 (mm) Journey	D M					
	X		X <sup>(1)</sup>		L	m (kg)
	MIN	MAX	MIN	MAX		
100	42	142	52	152	151	30
200	42	242	52	252	252	32
300	42	342	67	367	366	35
400	42	442	67	467	466	37
500	42	542	92	592	591	40
600	42	642	92	692	691	43
800	42	842	107	907	906	48
1000	42	1042	117	1117	1116	53
1200	42	1242	142	1342	1341	58

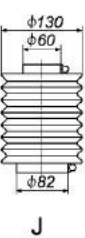

J

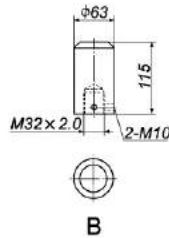

B

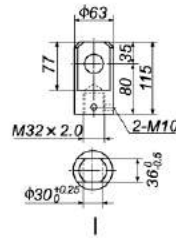

I

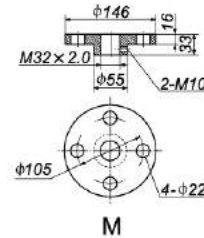

M

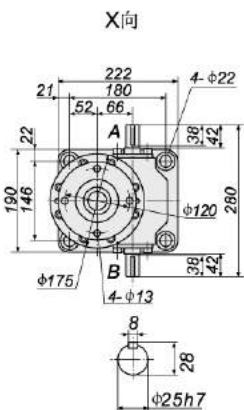

JWM100UR

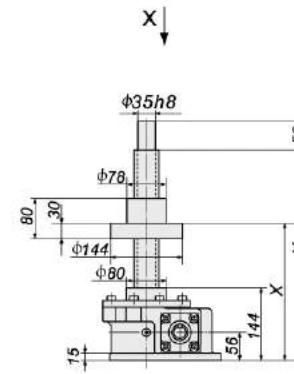

JWM100DR

行程 (mm) Journey	U R				
	X		Y		m (kg)
	MIN	MAX	MIN	MAX	
100	184	284	344	344	32
200	184	384	444	444	33
300	184	484	544	544	34
400	184	584	644	644	36
500	184	684	744	744	37
600	184	784	844	844	38
800	184	984	1044	1044	41
1000	184	1184	1244	1244	43
1200	184	1384	1444	1444	45

行程 (mm) Journey	D R				
	X		Y		m (kg)
	MIN	MAX	MIN	MAX	
100	115	215	225	32	
200	115	315	325	33	
300	115	415	425	34	
400	115	515	525	36	
500	115	615	625	37	
600	115	715	725	38	
800	115	915	925	41	
1000	115	1115	1125	43	
1200	115	1315	1325	45	

注: X<sup>(1)</sup>为加防尘罩时尺寸。

Note: "X<sup>(1)</sup>" is the dimension of jack with dust hood.



JWM150

JWM150US

JWM150DS

行程 (mm) Journey	U S				L	m (kg)
	X		X <sup>(1)</sup>			
	MIN	MAX	MIN	MAX		
100	183	283	193	293	151	33
200	183	383	193	393	252	35
300	183	483	208	508	366	38
400	183	583	208	608	466	41
500	183	683	233	733	591	45
600	183	783	233	833	691	47
800	183	983	248	1048	906	53
1000	183	1183	258	1258	1116	59
1200	183	1383	283	1483	1341	65

行程 (mm) Journey	D S				L	m (kg)
	X		X <sup>(1)</sup>			
	MIN	MAX	MIN	MAX		
100	42	142	52	152	151	33
200	42	242	52	252	252	35
300	42	342	67	367	366	38
400	42	442	67	467	466	41
500	42	542	92	592	591	45
600	42	642	92	692	691	47
800	42	842	107	907	906	53
1000	42	1042	117	1117	1116	59
1200	42	1242	142	1342	1341	65

JWM150UM

JWM150DM

行程 (mm) Journey	U M				L	m (kg)
	X		X <sup>(1)</sup>			
	MIN	MAX	MIN	MAX		
100	219	319	229	329	151	37
200	219	419	229	429	252	40
300	219	519	244	544	366	43
400	219	619	244	644	466	46
500	219	719	269	769	591	49
600	219	819	269	869	691	52
800	219	1019	284	1084	906	58
1000	219	1219	294	1294	1116	64
1200	219	1419	319	1519	1341	69

行程 (mm) Journey	D M				L	m (kg)
	X		X <sup>(1)</sup>			
	MIN	MAX	MIN	MAX		
100	42	142	52	152	151	37
200	42	242	52	252	252	40
300	42	342	67	367	366	43
400	42	442	67	467	466	46
500	42	542	92	592	591	49
600	42	642	92	692	691	52
800	42	842	107	907	906	58
1000	42	1042	117	1117	1116	64
1200	42	1242	142	1342	1341	69

J

B

I

M

JWM150UR

JWM150DR

行程 (mm) Journey	U R				L	m (kg)
	X		Y			
	MIN	MAX	MIN	MAX		
100	214	314	314	379	40	
200	214	414	414	479	42	
300	214	514	514	579	43	
400	214	614	614	679	45	
500	214	714	714	779	46	
600	214	814	814	879	48	
800	214	1014	1014	1079	51	
1000	214	1214	1214	1279	54	
1200	214	1414	1414	1479	57	

行程 (mm) Journey	D R				L	m (kg)
	X		Y			
	MIN	MAX	MIN	MAX		
100	128	228	239	40		
200	128	328	339	42		
300	128	428	439	43		
400	128	528	539	45		
500	128	628	639	46		
600	128	728	739	48		
800	128	928	939	51		
1000	128	1128	1139	54		
1200	128	1328	1339	57		

注: X<sup>(1)</sup> 为加防尘罩时尺寸。

Note: "X<sup>(1)</sup>" is the dimension of jack with dust hood.



JWM200

行程 (mm) Journey	U S					
	X		X <sup>(1)</sup>		L	m (kg)
	MIN	MAX	MIN	MAX		
100	203	303	213	313	151	42
200	203	403	213	413	252	45
300	203	503	228	528	366	49
400	203	603	228	628	466	53
500	203	703	253	753	591	57
600	203	803	253	853	691	60
800	203	1003	268	1068	906	67
1000	203	1203	278	1278	1116	74
1200	203	1403	303	1503	1341	81

行程 (mm) Journey	D S					
	X		X <sup>(1)</sup>		L	m (kg)
	MIN	MAX	MIN	MAX		
100	42	142	52	152	151	42
200	42	242	52	252	252	45
300	42	342	67	367	366	49
400	42	442	67	467	466	53
500	42	542	92	592	591	57
600	42	642	92	692	691	60
800	42	842	107	907	906	67
1000	42	1042	117	1117	1116	74
1200	42	1242	142	1342	1341	81

行程 (mm) Journey	U M					
	X		X <sup>(1)</sup>		L	m (kg)
	MIN	MAX	MIN	MAX		
100	252	352	262	362	151	51
200	252	452	262	462	252	55
300	252	552	277	577	366	58
400	252	652	277	677	466	62
500	252	752	302	802	591	66
600	252	852	302	902	691	69
800	252	1052	317	1117	906	76
1000	252	1252	327	1327	1116	83
1200	252	1452	352	1552	1341	90

行程 (mm) Journey	D M					
	X		X <sup>(1)</sup>		L	m (kg)
	MIN	MAX	MIN	MAX		
100	42	142	52	152	151	51
200	42	242	52	252	252	55
300	42	342	67	367	366	58
400	42	442	67	467	466	62
500	42	542	92	592	591	66
600	42	642	92	692	691	69
800	42	842	107	907	906	76
1000	42	1042	117	1117	1116	83
1200	42	1242	142	1342	1341	90

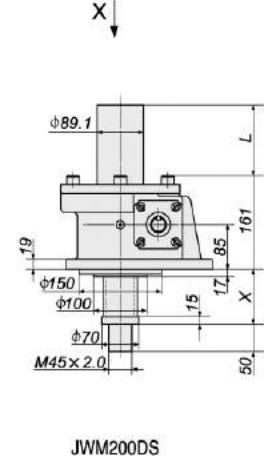
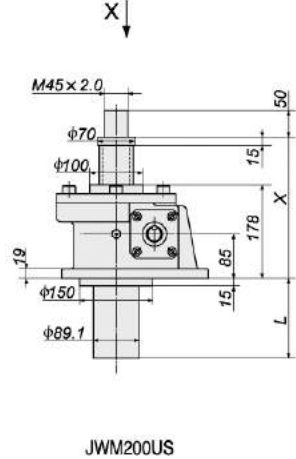
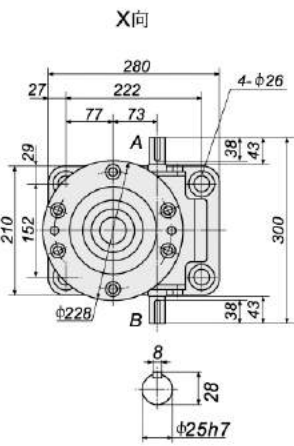

JWM200US

JWM200DS

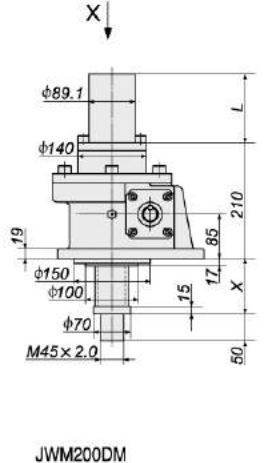
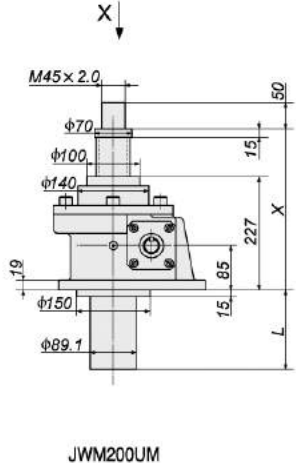
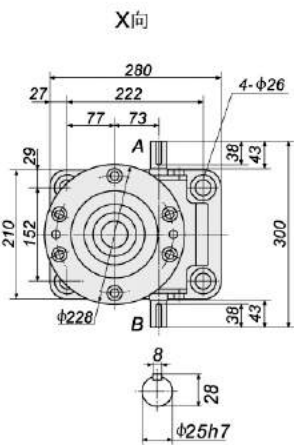

JWM200UM

JWM200DM

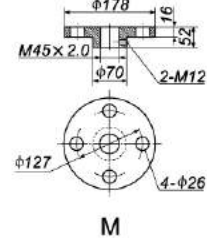
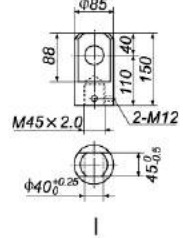
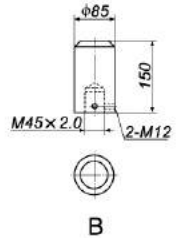
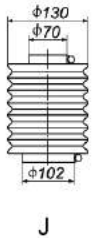

J

B

I

M

行程 (mm) Journey	U R				
	X		Y		m (kg)
	MIN	MAX	MIN	MAX	
100	237	337	422	56	
200	237	437	522	58	
300	237	537	622	60	
400	237	637	722	62	
500	237	737	822	64	
600	237	837	922	66	
800	237	1037	1122	71	
1000	237	1237	1322	75	
1200	237	1437	1522	79	

行程 (mm) Journey	D R				
	X		Y		m (kg)
	MIN	MAX	MIN	MAX	
100	151	251	261	56	
200	151	351	361	58	
300	151	451	461	60	
400	151	551	561	62	
500	151	651	661	64	
600	151	751	761	66	
800	151	951	961	71	
1000	151	1151	1161	75	
1200	151	1351	1361	79	

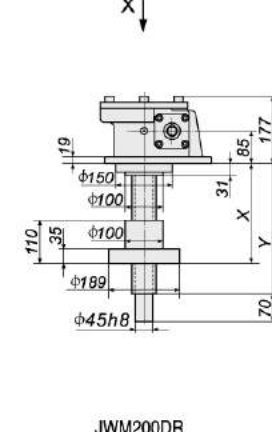
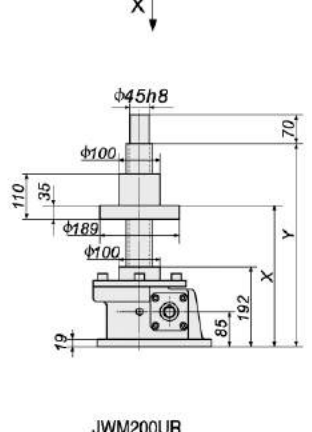
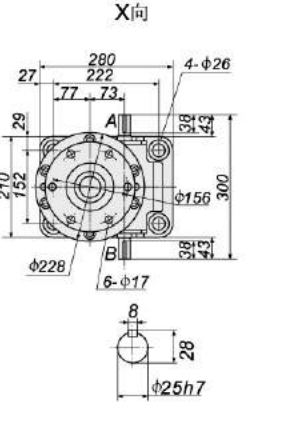

JWM200UR

JWM200DR

注: X<sup>(1)</sup> 为加防尘罩时尺寸。

Note: "X<sup>(1)</sup>" is the dimension of jack with dust hood.



JWM300

行程 (mm) Journey	U S					D S					m (kg)
	X		X <sup>(1)</sup>		L	X		X <sup>(1)</sup>		L	
	MIN	MAX	MIN	MAX		MIN	MAX	MIN	MAX		
100	255	355	265	365	160	55	155	65	165	160	118
200	255	455	265	465	260	55	255	65	265	260	123
300	255	555	280	580	375	55	355	80	380	375	128
400	255	655	280	680	475	55	455	80	480	475	134
500	255	755	295	795	590	55	555	95	595	590	139
600	255	855	295	895	690	55	655	95	695	690	145
800	255	1055	310	1110	905	55	855	110	910	905	155
1000	255	1255	330	1330	1125	55	1055	130	1130	1125	167
1200	255	1455	340	1540	1335	55	1255	140	1340	1335	177
1500	255	1755	365	1865	1660	55	1555	165	1665	1660	194

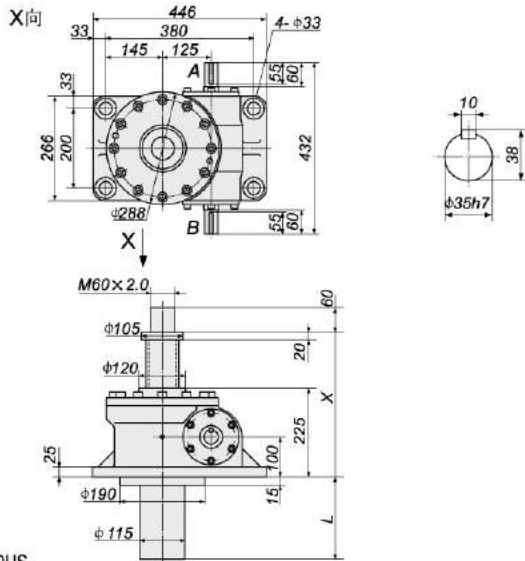

JWM300US

JWM500

行程 (mm) Journey	U S					D S					m (kg)
	X		X <sup>(1)</sup>		L	X		X <sup>(1)</sup>		L	
	MIN	MAX	MIN	MAX		MIN	MAX	MIN	MAX		
100	315	415	320	420	165	55	155	60	160	165	248
200	315	515	320	520	265	55	255	60	260	265	260
300	315	615	340	640	385	55	355	80	380	385	273
400	315	715	340	740	485	55	455	80	480	485	284
500	315	815	350	850	395	55	555	90	590	395	297
600	315	915	350	950	695	55	655	90	690	695	308
800	315	1115	365	1165	910	55	855	105	905	910	332
1000	315	1315	380	1380	1125	55	1055	120	1120	1125	357
1200	315	1515	390	1590	1335	55	1255	130	1330	1335	380
1500	315	1815	410	1910	1665	55	1555	150	1650	1665	417
2000	315	2315	445	2445	2190	55	2055	185	2185	2190	477

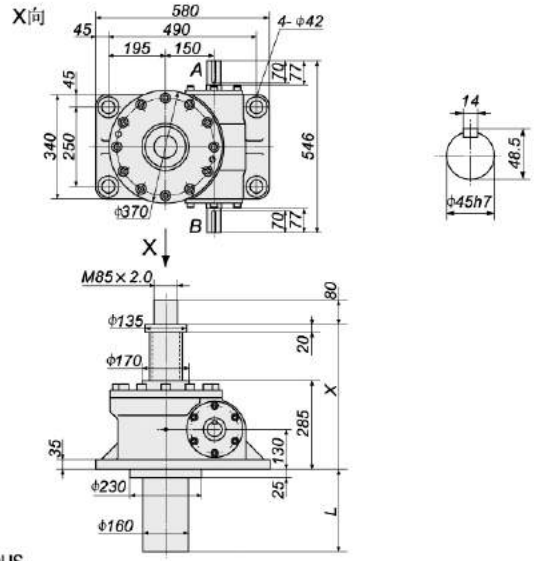

JWM500US

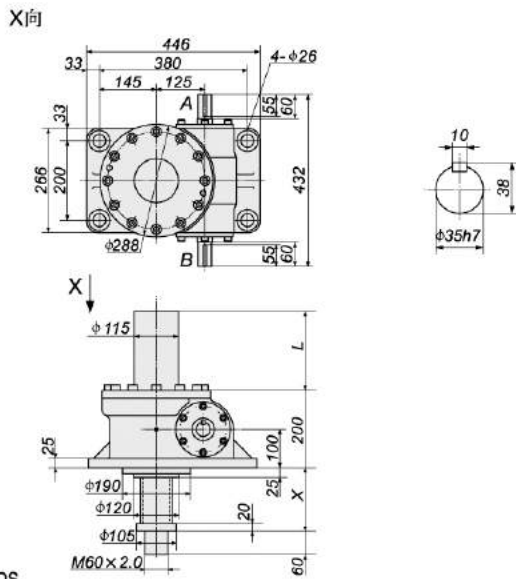

JWM300DS

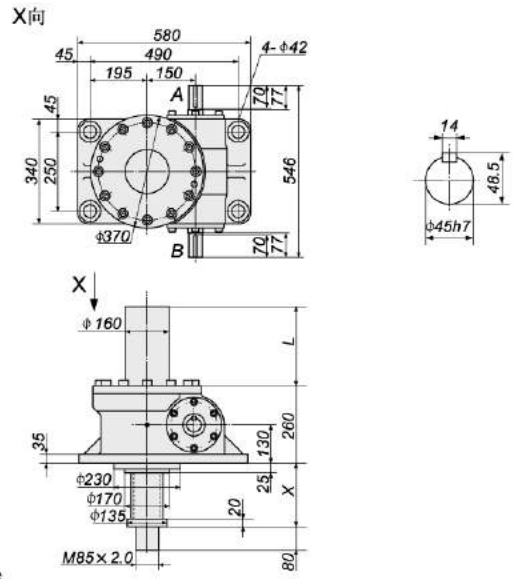

JWM500DS

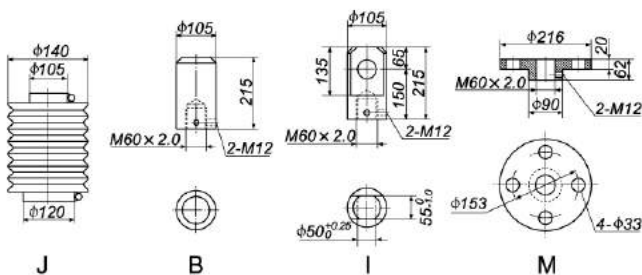

J B I M

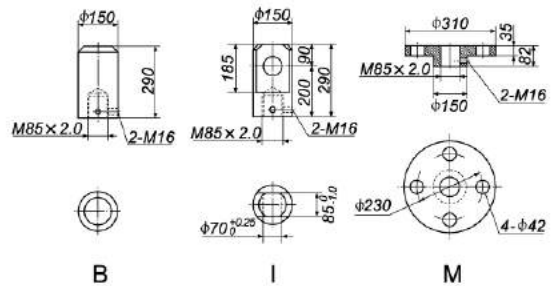

J B I M

注: X<sup>(1)</sup> 为加防尘罩时尺寸。

Note: "X<sup>(1)</sup>" is the dimension of jack with dust hood.

JW



JWM750

行程 (mm) Journey	U S					D S					m (kg)
	X		X <sup>(1)</sup>		L	X		X <sup>(1)</sup>		L	
	MIN	MAX	MIN	MAX		MIN	MAX	MIN	MAX		
100	370	470	380	480	165	70	170	80	180	165	370
200	370	570	380	580	265	70	270	80	280	265	384
300	370	670	395	695	385	70	370	95	395	385	401
400	370	770	395	795	485	70	470	95	495	485	415
500	370	870	410	910	595	70	570	110	610	595	431
600	370	970	410	1010	695	70	670	110	710	695	445
800	370	1170	425	1225	910	70	870	125	925	910	476
1000	370	1370	435	1435	1125	70	1070	135	1135	1125	506
1200	370	1570	450	1650	1335	70	1270	150	1350	1335	536
1500	370	1870	465	1965	1665	70	1570	165	1665	1665	581
2000	370	2370	500	2500	2190	70	2070	200	2200	2190	657

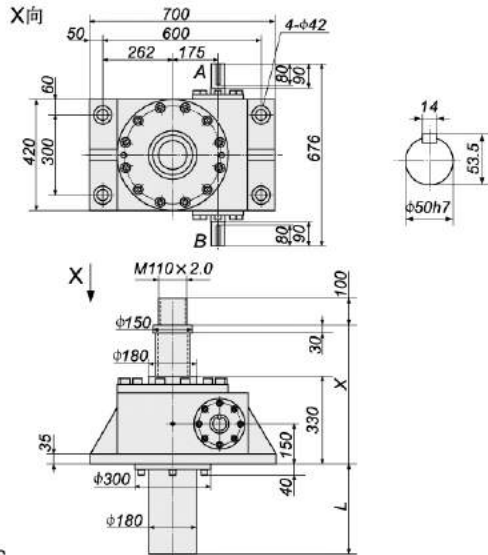

JWM750US

JWM1000

行程 (mm) Journey	U S					D S					m (kg)
	X		X <sup>(1)</sup>		L	X		X <sup>(1)</sup>		L	
	MIN	MAX	MIN	MAX		MIN	MAX	MIN	MAX		
100	450	550	460	560	165	70	170	80	180	165	748
200	450	650	460	660	265	70	270	80	280	265	766
300	450	750	475	775	385	70	370	95	395	385	787
400	450	850	475	875	485	70	470	95	495	485	805
500	450	950	485	985	595	70	570	105	605	595	824
600	450	1050	485	1085	695	70	670	105	705	695	842
800	450	1250	500	1300	910	70	870	120	920	910	881
1000	450	1450	510	1510	1125	70	1070	130	1130	1125	918
1200	450	1650	525	1725	1335	70	1270	145	1345	1335	957
1500	450	1950	545	2045	1665	70	1570	165	1665	1665	1014
2000	450	2450	575	2575	2190	70	2070	195	2195	2190	1109

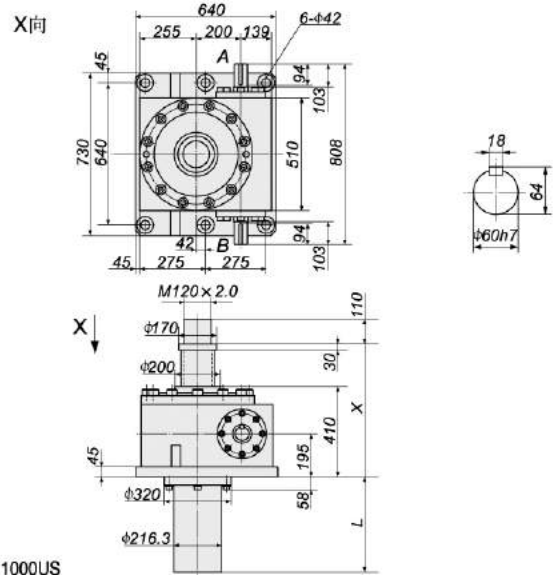

JWM1000US

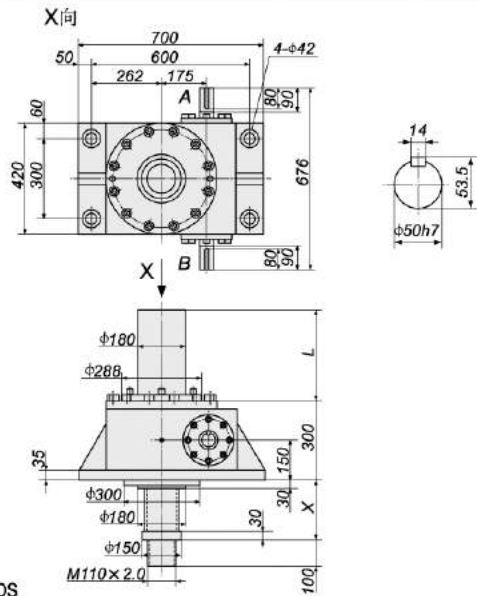

JWM750DS

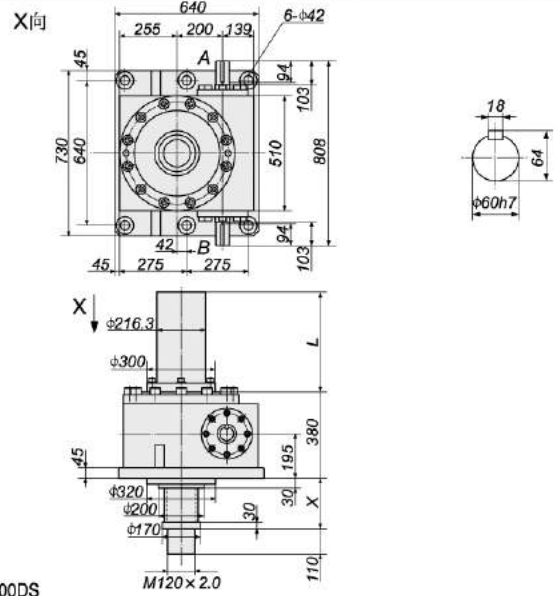

JWM1000DS

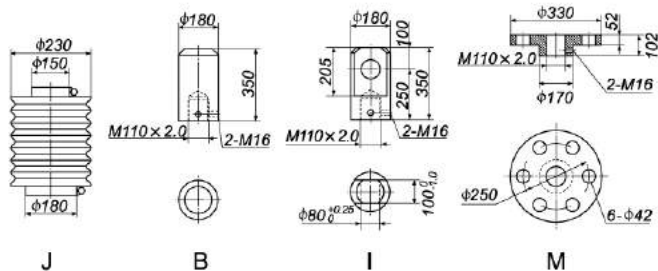

J

B

I

M

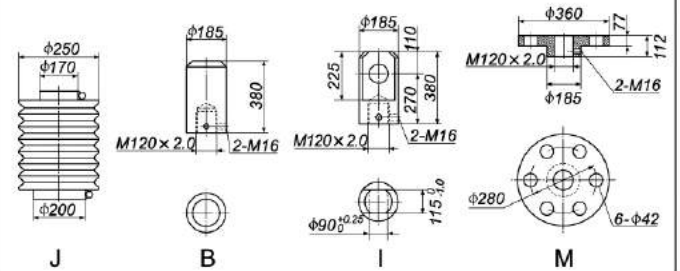

J

B

I

M

注: X<sup>(1)</sup> 为加防尘罩时尺寸。

Note: "X<sup>(1)</sup>" is the dimension of jack with dust hood.



厂址：山东省德州高新技术开发区蒙阴路2758号  
营销热线：0534-2796998 2787998 2783998 2763998  
传真：0534-8310998  
E-mail：[china@ludccd.com](mailto:china@ludccd.com)  
网址：[www.ludccd.com](http://www.ludccd.com)